



## Flowmeter Series FLOMID FX



### FLOMID FX Electromagnetic Flowmeter

Working pressure manufacturing according to PED 97/23/CE (Lloyd's Register Certificate N° 031)

#### Introduction

Modular design in two versions:

- Compact, sensor and electronics unit forming a single unit
- Separate, sensor and electronics separated, joined by a cable

Various possibilities of pipe fittings:

- Flange: EN 1092-1, ANSI, JIS standards etc.
- Sandwich: for EN 1092-1, ANSI, JIS flanges etc.
- Sanitary: DIN 11851 thread, ISO 2852 Clamp, SMS 1145 thread
- Sanitary welding: DIN 11850, ISO 2037 standards
- Working pressure manufacturing according to PED97/23/CE (Lloyd's Register Certificate N° 031)

Sensor liners PP, PTFE, PVDF & Hard rubber Electrodes in EN 1.4404 (SS 316L), Hastelloy C22 (UNS-06022), Zirconium, Titanium, Tantalum Exterior construction in EN 1.4404 (SS 316L).

#### Benefits

- Flow rate measurement is independent of the flow profile
- Pulsed coil excitation to obtain a minimum zero drift
- Readings are independent of density, temperature, viscosity and pressure
- Absence of obstructing elements gives zero pressure loss and will allow the pass of solids
- Can be mounted in any position, provided that the pipe is always full
- Low power consumption
- Good stability with temperature and age
- No moving parts provides zero maintenance
- Can be installed with short straight pipe sections (5DN / 3DN)
- Good chemical resistance of construction materials
- All electronic control units for use with all sensors

#### Technical data FLOMID FX sensor

- Accuracy:  $\pm 0.5\%$  of reading
- Working pressure: PN16 standard, on demand up to PN250
- Coupling according to EN 1092-1, ANSI, JIS, Sanitary
- DN3...DN500
- Working temperature: PP, -10...+80°C  
PTFE, PVDF, -20...+120°C  
Hard rubber, -20...+90°C  
(temperatures for sensor with separated electronics)





## Measurement Principle

The measurement principle is based on Faraday's induction law. A conductive liquid ( $>5\mu\text{S}/\text{cm}$ ) creates a voltage  $T_m$  when flowing in a pipe of diameter  $D$ , at an average velocity of  $V_m$ , through a magnetic field  $B$  (which is perpendicular to the flow direction). This voltage is proportional to the velocity of the liquid. Two electrodes, mounted perpendicular to the magnetic field inside the pipe, transmit the voltage  $T_m$  to the control unit.

$$T_m = B \times V_m \times D$$

- $T_m$  = Voltage across the electrodes
- $V_m$  = Liquid velocity
- $B$  = Magnetic field strength
- $D$  = Pipe diameter

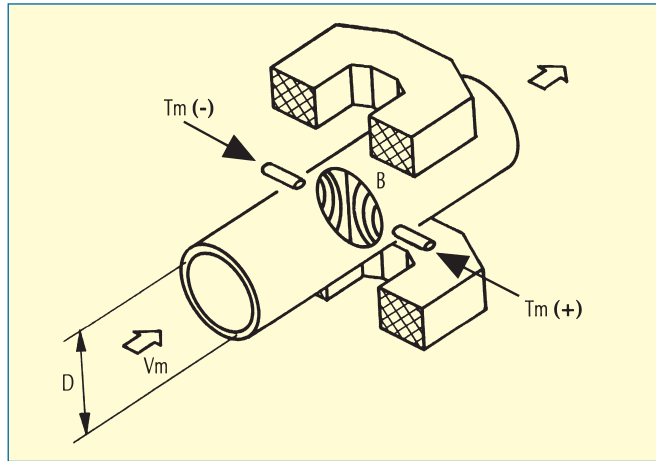

## Basic Installation Recommendations

**For the mechanical installation** the most important factor to be taken into consideration is that the pipe must always be full and the electrodes in contact with the liquid. To guarantee this, the metering body should be mounted with the electrodes in a horizontal plane and in a position so that the pipe will always be full, without air pockets.

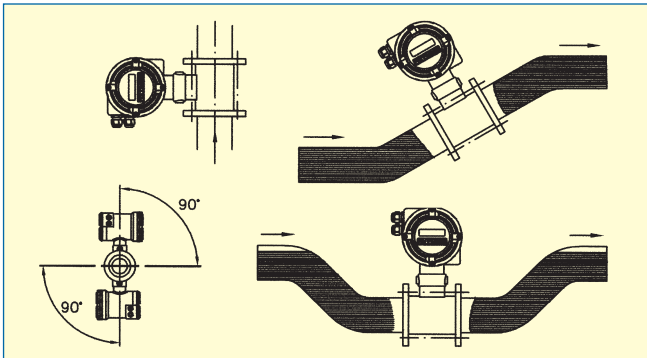

### Vibration

Fasten the pipe before and after the sensor.

Caution: Excessive vibration will need separate mounting of sensor and electronics.

With free runs of piping over 10 m long, mechanical supports are recommended to minimize external forces.

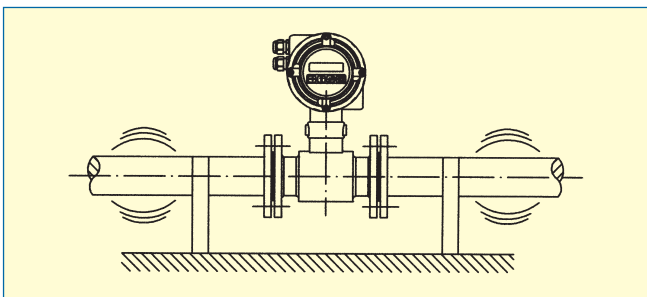

In installations where strong axial ground currents can be found, the earth connections should have at least  $50 \text{ mm}^2$  in contact with the liquid.

**Mixtures of different liquids.** The sensor should be installed a minimum of  $30\text{DN}$  from the point of mixture to avoid unstabilities in the readings.

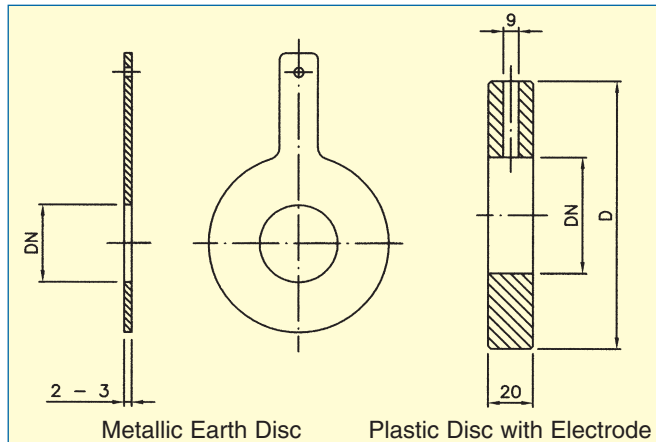

**A good earth** connection between the measuring body and the liquid can be considered as the most important factor for the correct working of the unit. In the event that the pipe is made of electrically conductive material, just connect the two earth wires to the pipe flanges, one to each side of the instrument body. If the inside of the pipe is plastic (or of any other non-conductive material) two earth discs and two more rubber washers, one on each side of the body, must be installed and the earth wires connected to the earth discs. This earth should be only used for the measuring body, do not connect other equipment to it since electrical interferences may cause problems.

**Straight sections of pipe** are necessary for the correct working of the flowmeter. Curves, pipe reductions, control elements and pumps should be at least 5DN upstream and 3DN downstream from the flowmeter.

**Valves** should be downstream from the flowmeter to keep the pipe full and to avoid vacuums which can damage the flowmeter liner.

**Pumps** should be upstream from the flowmeter to avoid vacuums.

When installing near curves, control elements and pumps, a minimum straight section of pipe must be installed before and after these elements (Minimum 5DN before and 3DN after).

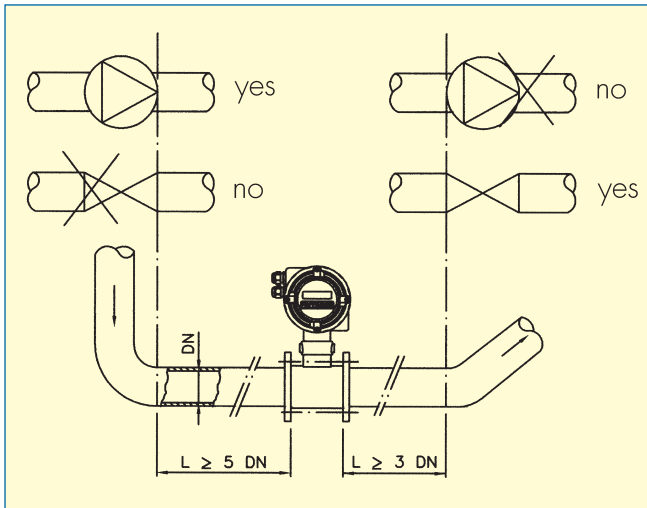

For abrasive liquids or liquids with particles in suspension, it is recommended to mount the flowmeter in a rising pipe. For a horizontal pipe the installation can be made as in the following drawing with a valve system for cleaning.

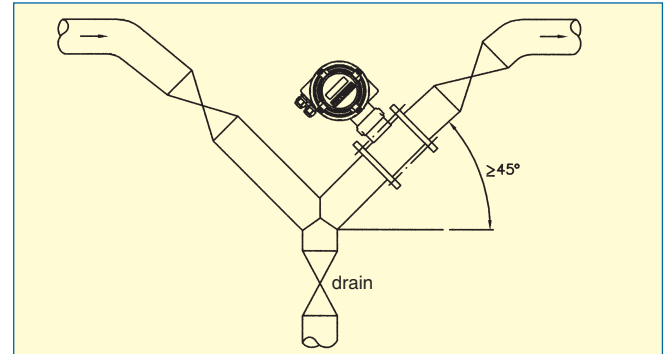

### Measuring Precision (DIN 19200)

Ambient temperature	20°C ± 2°C
Liquid temperature	20°C ± 2°C
Power supply	± 1%
Heat up time	30 min.
Minimum straight pipe	10DN & 5DN

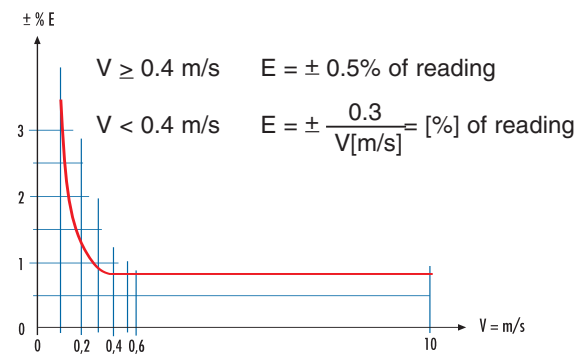

### Pressure loss when reducing the pipe diameter

In installations where, due to the low flow rate, it is necessary to reduce the pipe diameter to be able to install a flowmeter with a nominal diameter less than the pipe diameter, this should be done using a reduction cone with an angle of less than 8° in order to avoid turbulences which can give false readings.

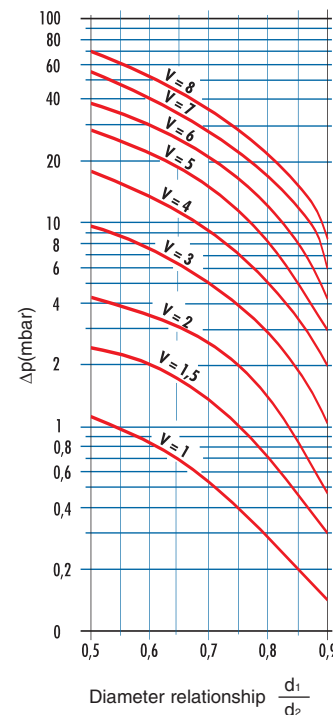
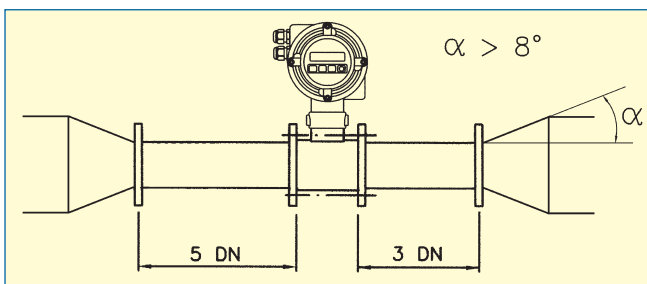
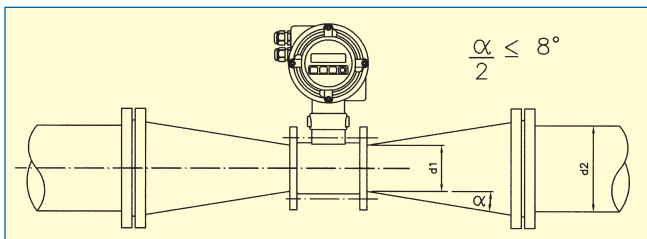

The graph shows the pressure loss ( $\Delta P$ ) for water at different velocities and pipe reductions.

## Flow rate table

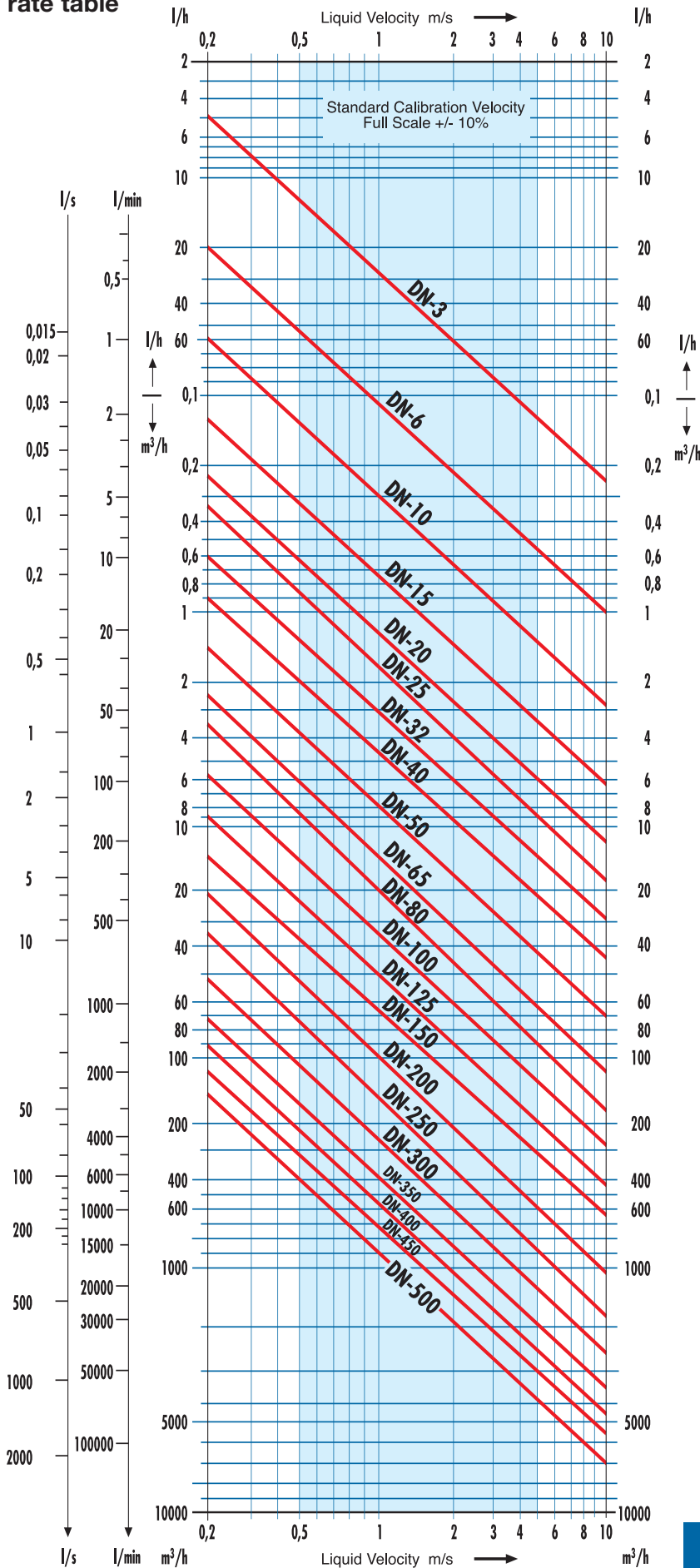

## Metering body selection

The diagram shows the relation between the liquid speed and the flow rate for different body sizes. The metering body diameter should be chosen to obtain a maximum normal working liquid velocity of about 3-4 m/s. The minimum working liquid velocity should not be below 0.5 m/s.

A recommended working liquid velocity is between 1 and 3 m/s. When the liquid has solids in suspension, it is better to work between 3 and 5 m/s to avoid sedimentation in the pipe and metering body.



Flomid-2FX with XT5 electronics



Flomid-6FX with XT5 electronics

## Flomid-0FX

### Compact electronics

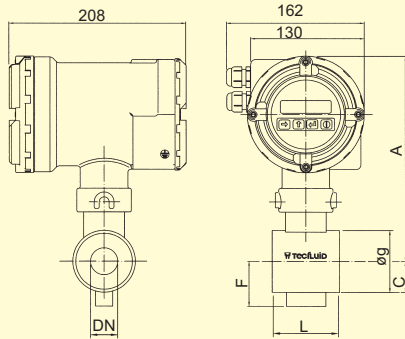

### Separate electronics

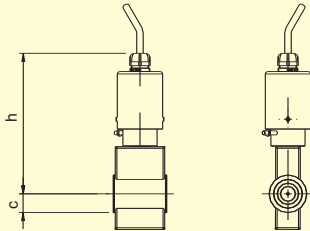

### EN 1092-1 sandwich mounting

(Dimensions in mm)

DN	PN	A	Ax	C	g	Wheight (kg)	F	L	h
3*	16	262	276	23	46	6,5	45	64	178
6*	16	262	276	23	46	6,5	45	64	178
10*	16	262	276	23	46	6,5	45	64	178
15*	16	265	279	25	50	6,8	47	64	182
20*	16	272	286	31	61	7,2	47	64	188
25*	16	243	257	35	70	8,2	-	79	160
32	16	250	264	41	82	9	-	79	167
40	16	256	270	46	92	9,5	-	99	173
50	16	263	277	53	106	10,3	-	99	180
65	16	275	289	63	126	11	-	119	192
80	16	283	297	71	142	12,2	-	119	200
100	10	293	307	81	162	14	-	164	210
125	10	310	324	96	192	17,5	-	164	226
150	10	322	336	108	217	19,6	-	164	238

\*h+24 mm



### ANSI B16.5 sandwich mounting

(Dimensions in inches)

DN	PN (lbs)	A	Ax	C	g	Weight (lbs)	F	L	h
*1/2"	16	262	276	23	46	6,5	45	64	178
	(150)	(10,3)	(10,8)	(0,90)	(1,81)	(14,3)	(1,7)	(2,51)	(7,0)
3/4"	16	265	279	25	50	6,8	47	64	182
	(150)	(10,4)	(10,9)	(0,98)	(1,96)	(14,9)	(1,8)	(2,51)	(7,1)
1"	16	275	289	31	61	7,2	47	64	188
	(150)	(10,8)	(11,3)	(1,22)	(2,40)	(15,8)	(1,8)	(2,51)	(7,40)
1 1/4"	16	243	257	35	70	8,2	-	79	160
	(150)	(9,6)	(10,1)	(1,37)	(2,75)	(18,0)	-	(3,11)	(6,2)
1 1/2"	16	250	264	41	82	9	-	79	167
	(150)	(9,8)	(10,3)	(1,61)	(3,22)	(19,84)	-	(3,11)	(6,5)
2"	16	256	270	46	92	9,5	-	99	173
	(150)	(10,0)	(10,6)	(1,81)	(3,62)	(20,9)	-	(3,89)	(6,8)
2 1/2"	16	263	277	53	106	10,3	-	99	180
	(150)	(10,3)	(10,9)	(2,08)	(4,17)	(22,7)	-	(3,89)	(7,1)
3"	16	275	289	63	126	11	-	119	192
	(150)	(10,8)	(11,3)	(2,48)	(4,96)	(24,2)	-	(4,68)	(7,5)
4"	16	293	307	81	162	14	-	164	210
	(150)	(11,5)	(12)	(3,18)	(6,37)	(30,8)	-	(6,45)	(8,2)
5"	16	310	324	96	192	17,5	-	164	226
	(150)	(12,7)	(12,7)	(3,77)	(7,55)	(38,5)	-	(6,45)	(8,8)
6"	16	322	336	108	217	19,6	-	164	238
	(150)	(12,6)	(13,3)	(4,25)	(8,54)	(43,2)	-	(6,45)	(9,3)

\*Equal dimensions for 1/8" and 3/8"

# FLOMID-2FX / FLOMID-4 FX

## EN 1092-1, ANSI Flanges

### MX Compact electronics

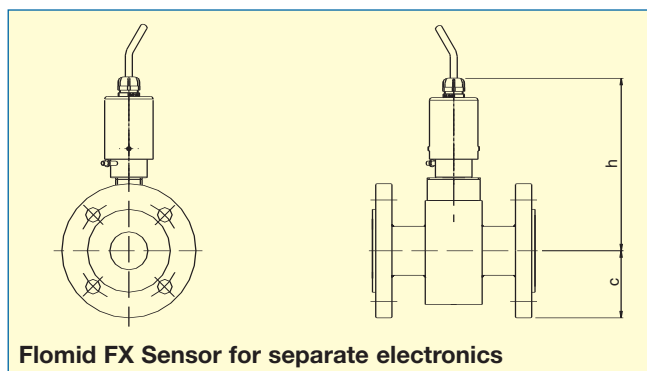
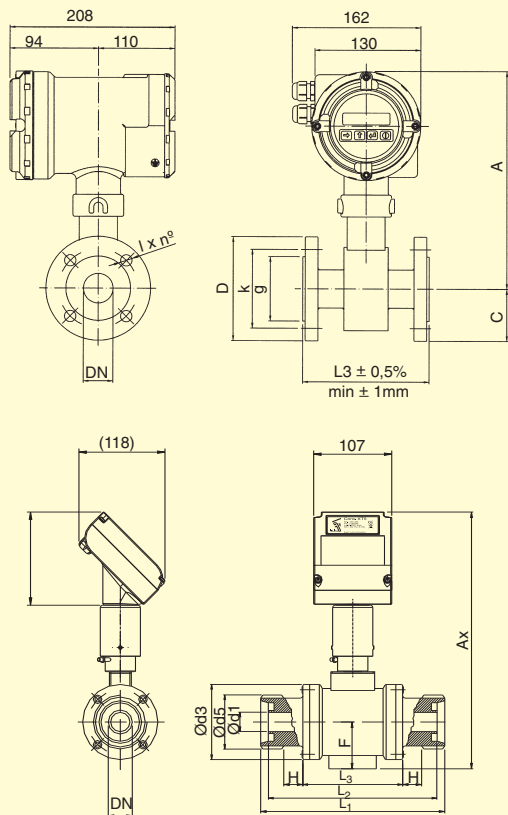

Flomid FX Sensor for separate electronics

FLANGES mm (inch)				DIMENSIONS mm (inch)												
DIN 2632-2635		ANSI B16.5		A	Ax	L	D	K	g	lxn°	h	D	K	g	lxn°	Weight
DN	PN	DN	PN	mm	mm	mm	DIN	DIN	DIN	DIN	DIN	ANSI	ANSI	ANSI	ANSI	kg
	(bar)		(lbs)	(inches)	(inches)	(inches)										(lbs)
1-10	16	3/8"	150	285 (11,2)	299 (11,7)	150 (5,90)	90	60	40	14x4	205 (8,1)	88,9				4,5 (9,92)
15	16	1/2"	150	285 (11,2)	299 (11,7)	150 (5,90)	95	65	45	14x4	205 (8,1)	88,9	60,3	34,9	16x4	4,8 (10,60)
20	16	3/4"	150	285 (11,2)	299 (11,7)	150 (5,90)	105	75	58	14x4	205 (8,1)	98,4	69,8	42,9	16x4	6 (13,22)
25	16	1"	150	285 (11,2)	299 (11,7)	150 (5,90)	115	85	68	14x4	205 (8,1)	107,9	79,4	50,8	16x4	7,5 (16,53)
32	16	1 1/4"	150	330 (13,0)	344 (13,5)	150 (5,90)	140	100	78	18x4	250 (9,9)	117,5	88,9	63,5	16x4	8 (17,63)
40	16	1 1/2"	150	330 (13,0)	344 (13,5)	150 (5,90)	150	110	88	18x4	250 (9,9)	127,5	98,4	73	16x4	8,5 (18,74)
50	16	2"	150	347 (13,6)	361 (14,2)	200 (7,87)	165	125	102	18x4	267 (10,5)	152,4	120,6	92,1	19x4	10 (22,05)
65	16	2 1/2"	150	367 (14,5)	381 (15)	200 (7,87)	185	145	122	18x4	287 (11,3)	177,8	139,7	104,8	19x4	11 (24,25)
80	16	3"	150	367 (14,5)	381 (15)	200 (7,87)	200	160	138	18x4	287 (11,3)	190,5	152,4	127	19x4	12,5 (27,55)
100	16	4"	150	418 (16,4)	432 (17)	250 (9,84)	220	180	158	18x4	338 (13,3)	228,6	190,5	157,2	19x8	15 (33,06)
125	16	5"	150	443 (17,4)	457 (18)	250 (9,84)	250	210	188	18x4	363 (14,3)	254	215,9	185,7	23x8	18,5 (40,78)
150	16	6"	150	473 (18,6)	488 (19,2)	300 (11,81)	285	240	212	22x8	393 (15,5)	279,4	241,3	215,9	23x8	20,6 (45,41)
200	10	8"	150	523 (20,6)	537 (21,1)	350 (13,77)	340	295	268	22x8	443 (17,5)	342,9	298,4	269,9	23x8	32 (70,54)
250	10	10"	150	575 (22,6)	589 (23,1)	400 (15,74)	395	350	320	22x8	495 (19,5)	406,4	361,9	323,8	25x12	45 (99,20)
300	10	12"	150	621 (24,5)	634 (25)	500 (19,68)	445	400	370	22x8	541 (21,3)	482,6	431,8	381	25x12	52 (114,63)
350	10	14"	150	671 (26,4)	685 (27)	500 (19,69)	505	460	430	22x8	591 (23,3)	533,4	476,2	412,7	30x12	62 (136,68)
400	10	16"	150	721 (28,4)	735 (29)	600 (23,62)	565	515	482	26x16	641 (25,3)	596,9	539,7	469,9	30x16	76 (167,54)
500	10	18"	150	825 (32,5)	839 (33)	600 (23,62)	670	620	585	26x20	745 (29,4)	635	577,8	533,4	33x16	98 (216,04)

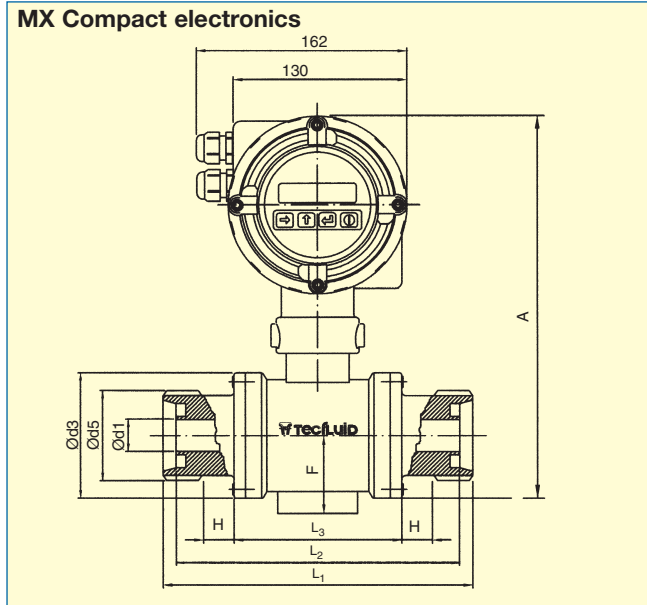
**DIN 11851**
**FLOMID 1 FX**

**DIN 11851**
**FLOMID-1FX**

DN	10	15	20	25	32	40	50	65	80	100
NW Ø d <sub>1</sub>	10	16	20	26	32	38	50	66	81	100
Ø d <sub>5</sub>	Rd 28 x 1/8"	Rd 34 x 1/8"	Rd 34 x 1/6"	Rd 52 x 1/6"	Rd 58 x 1/6"	Rd 65 x 1/6"	Rd 78 x 1/6"	Rd 95 x 1/6"	Rd 110 x 1/4"	Rd 130 x 1/4"
H	28	28	28	29	29	29	29	31	27	28
Ø d <sub>3</sub>	60	64	70	80	90	100	114	144	160	180
A (Ax) <sup>1</sup>	268	272	275	280	286	290	300	310	318	328
L <sub>1</sub>		200		220		240		280		330
L <sub>2</sub>		192	188	206		226		264		310
L <sub>3</sub>		120		134		154		186		234
F	45	48	54	-	-	-	-	-	-	-

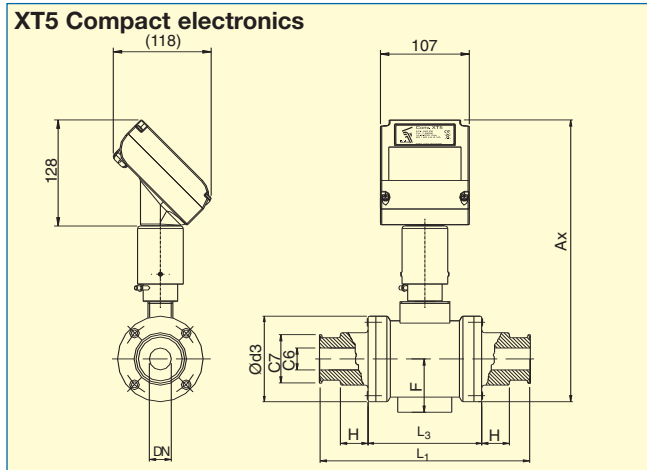
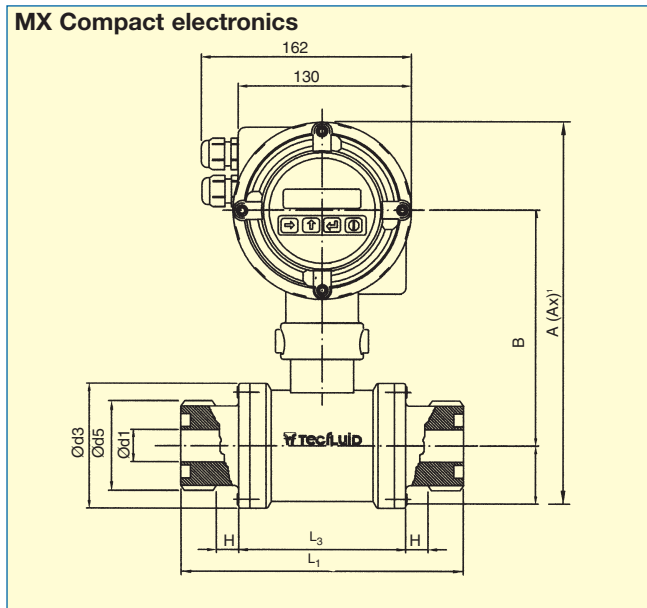
1) Ax= A + 14 mm (1/2") (with XT5 electronics)

**FLOMID-1...3FX**

**ISO 2853**
**FLOMID-3FX**

**ISO 2853**
**FLOMID-3FX**

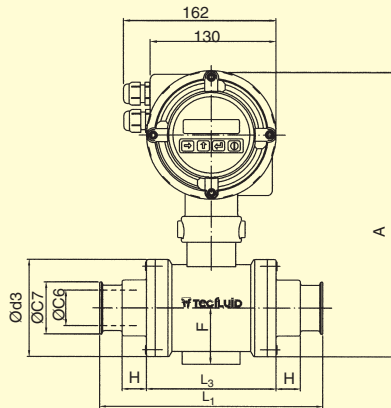
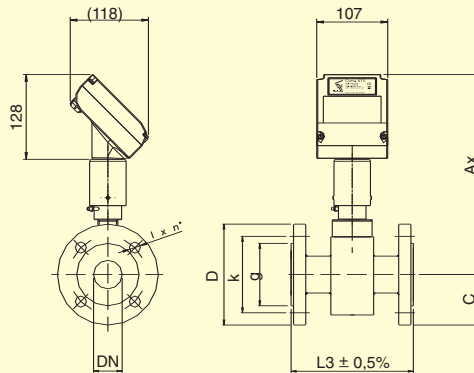
DN	25	32	38	51	63,5	76
NW Ø d <sub>1</sub>	22,5	29,5	35,5	48,5	60,5	72,9
Ø d <sub>5</sub>	Rd 40 x 1/6"	Rd 48 x 1/6"	Rd 60 x 1/6"	Rd 70 x 1/6"	Rd 85 x 1/6"	Rd 98 x 1/6"
H	25	25	25	25	25	25
Ø d <sub>3</sub>	80	90	100	114	144	160
A (Ax) <sup>1</sup>	280	286	290	300	310	318
L <sub>1</sub>		220		240		280
L <sub>2</sub>		134		154		186
Equival. DIN-DN	25	32	40	50	65	80

1) Ax= A + 14 mm (1/2") (with XT5 electronics)

**CLAMP ISO 2852:1993**
**FLOMID-6FX**
**MX Compact electronics**

**XT5 Compact electronics**

**CLAMP ISO 2852 : 1993**
**FLOMID-6FX**

Coupling dimensions	-	-	1/2"	-	-	1"	1 1/4"	1 1/2"	2"	2 1/2"	3"	4"
Equival. DIN-DN	6	6	10	15	20	25	32	40	50	65	80	100
pipe outside ø	8	12	12,7	17,2	21,3	25	33,7	38	51	63,5	76,1	101,6
Ø C <sub>6</sub>	6	10	10,7	15,2	19,3	22,6	31,3	35,6	48,6	60,3	72,9	97,6
Ø C <sub>7</sub>	34	34	34	34	34	50,5	50,5	50,5	64	77,5	91	119
H	30	30	30	30	30	31	31	31	31	34	34	34
Ø d <sub>3</sub>	60	60	60	64	70	80	90	100	114	144	160	180
A (Ax) <sup>1)</sup>	268	268	268	272	275	280	286	290	300	310	318	328
L <sub>3</sub>			120			134		154		186		234
L <sub>1</sub>			200			220		240		280		330
F	45	45	45	48	54	-	-	-	-	-	-	-

1) Ax= A + 14 mm (1/2") (with XT5 electronics)

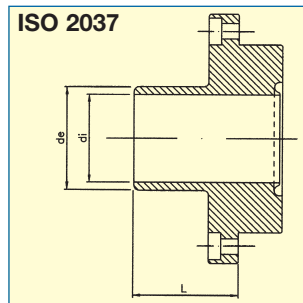
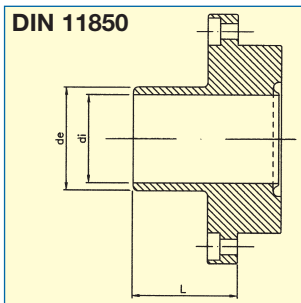
**DIN 11850 (weld-on connections) FLOMID-D10FX**

DN	10	15	25	40	50	65	80
d <sub>e</sub>	12(0,47)	18(0,71)	40(1,57)	52(2,05)	68(2,03)	83(3,27)	83(3,27)
d <sub>i</sub>	10(0,39)	16(0,63)	26(1,02)	38(1,50)	50(1,97)	66(2,60)	81(3,19)
L	50(2)		63(2,48)			60(2,36)	



**ISO 2037 (weld-on connections) FLOMID-I70FX**

DN	10	15	25	40	50	65	80
d <sub>e</sub>	12(0,47)	18(0,71)	25,6(1,01)	38,6(1,52)	51,6(2,03)	64,1(2,52)	76,6(3,02)
d <sub>i</sub>	10(0,39)	16(0,63)	22,6(0,89)	35,6(1,40)	48,6(1,97)	60,3(2,37)	72,9(2,87)
L	50(2)		63(2,48)			60(2,36)	

\*The rest of the dimensions as with FLOMID 1 (page 7)  
( ) dimensions in inches

**ISO 2853**
**FLOMID-I38FX**

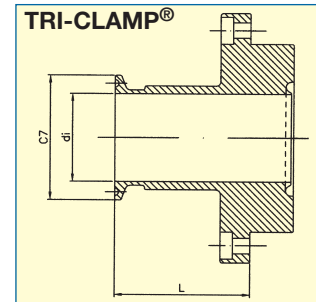
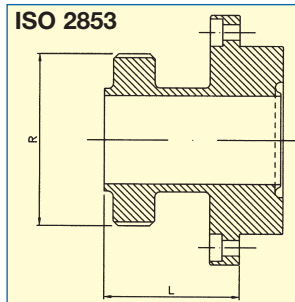
DN	15	20	25	40	50	65	80
R	1/2"	3/4"	1"	1 1/2"	2"	2 1/2"	3"
L	50(2)		63(2,48)			60(2,36)	

**TRI-CLAMP®**
**FLOMID-D30FX**

Coupling dimensions	1"	1 1/2"	2"	2 1/2"	3"	4"
Equival. DIN-DN	25	40	50	65	80	100
C <sub>7</sub>	50,4	50,4	64	77,8	91	119
d <sub>i</sub>	22,1	34,8	47,5	60,2	72,9	97,4
L	63(2,48)			60(2,36)		

® trade mark the Tri-Clover inc.

## Liner materials. Temperature, Pressure and Vacuum (20°C reference temperature)

DN	PTFE				PTFE / PVDF				PP				HARD rubber			
	Flomid 2 FX, Flomid 4 FX				Flomid 0 FX Flomid 1, 3, 5, 7 FX				Flomid 0 FX				Flomid 2 FX, Flomid 4 FX			
	PN		Vacuum <sup>(1)</sup>		PN		Vacuum <sup>(1)</sup>		PN		Vacuum <sup>(1)</sup>		PN		Vacuum <sup>(1)</sup>	
	DIN2501 <sup>(3)</sup>	ANSI B 16.5 <sup>(4)</sup>	mbar	psi	DIN2501	ANSI B 16.5	mbar	psi	DIN2501	ANSI B 16.5	mbar	psi	DIN2501	ANSI B 16.5	mbar	psi
3			0	0												
6																
10	16 > 40	150 > 300	∇	∇	16	150 > 300	60	0,9	16	150 > 300	100	1,5				
15																
20			0	0												
25			80	1,2											100	1,5
32	16 > 40	150 > 300	∇	∇	16	150 > 300	100	1,5	16	150 > 300	180	2,7	16 > 40	150 > 300	∇	∇
40																
50			500	7,5			600	9			700	10,5			200	3
65	16 > 40	150 > 300	150	2,2	16	150 > 300	150	2,2	16	150 > 300	200	3	16 > 40	150 > 300	120	1,8
80			650	9,7			700	10,5			800	12			250	3,7
100			250	3,7			300	4,5			380	5,7			280	4,2
125	16	150	750	11,2	10	150 > 300	800	12	10	150 > 300	900	13,5	10	150	∇	∇
	∇		450	6,7			480	7,2			650	9,7	∇			
150	40		800	12			900	13,5			1000	15	40		400	6
200			450	6,7											250	3,75
			900	13,5												
250	10	150	500	7,5									10	150	∇	∇
300	∇		1000	15									∇		450	6,7
350			750	11,2									40		500	7,5
400	40		∇	∇											∇	∇
500			1000	15											600	9
Max. Temp.	-20...+120°C (-4...+248°F)				-20...+120°C (-4...+248°F)				-10...+80°C (14...+176°F)				-20...+90°C (-14...+194°F)			
Limit <sup>(2)</sup>	130°C (266°F)				130°C (266°F)				—				—			

(1) In mbar absolute 40°C and 80°C reference temperature  
 (2) Maximum 30'. On order up to 180°C and PN200

(3) bar  
 (4) lbs

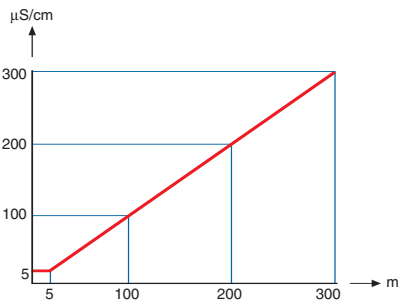

### Wiring minimum conductivity required depending on cable length

- Cable for separate electronics:  
 PAR-POS 2 x 2 x 0.34 (recommended)

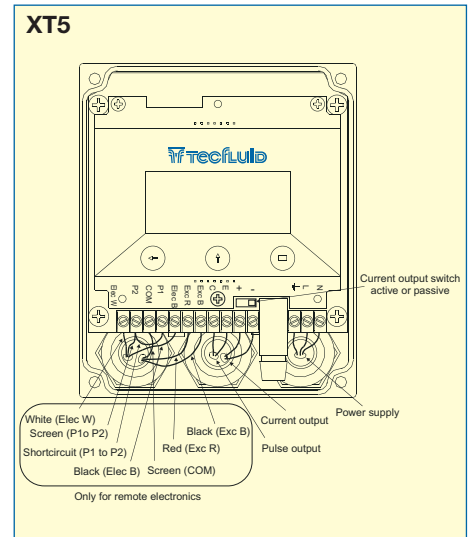
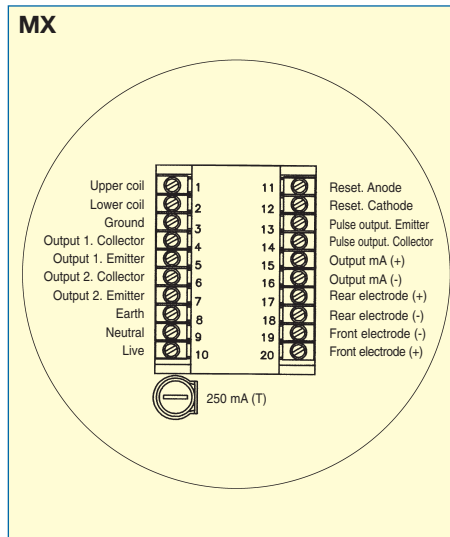

## Series MX Electronic Control Units

Different models of electronic control units are available to comply with the options of flow indication, maximum/minimum flow rate controls, analog outputs, pulse outputs. All are compatible with the different Flomid FX sensor models.

### For compact mounting directly on the sensor

- Series MX, with local indication, mA and pulse outputs, alarms, totalizer, etc.

### For wall and pipe bracket mounting

- Series MX/M (wall mounting) and MX/T (pipe mounting)

## Pulsed coil excitation

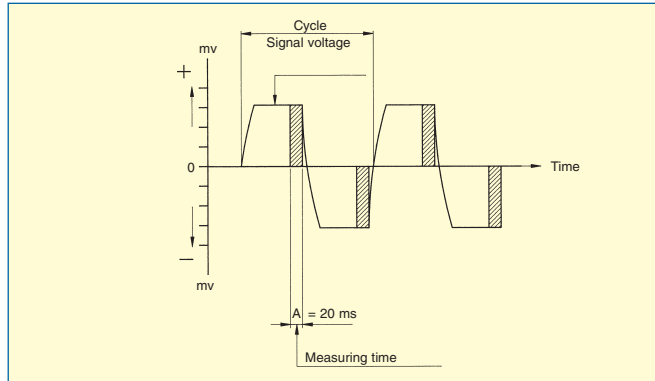

## Series MX, Electronic Control Units Technical Data

- Painted coated injected aluminium housing. IP67 degree of protection
- Programming via front tactile push buttons
- Totalising and partial volume counters
- Programmable batching volume with remote input for starting
- Magnetic field: 6.25 Hz square wave for 50 Hz mains  
7.5 Hz square wave for 60 Hz mains
- Mains supply: 12 V, 24 V, 110 V, 120 V, 220 V, 240 Vac,  $\pm 10\%$ , 50/60 Hz  
**24 Vdc** (others on demand)
- Power consumption: <10 VA
- Min. Flowrate cut off: Programmable
- Measuring range: 0...10 m/s
- Display: 16 character x 2 lines LCD  
6 languages to be selected.  
Program for auto-edition of other languages
- Flowrate indication: User programmable measuring units
- Analog output: 4...20 mA programmable

- Programmable pulse output mode:  
Flowrate x Pulses/volume unit  $< /2$  pulses/s
- Programmable frequency output mode: 10..1000 Hz
- Logic outputs: Two programmable transistor outputs for flowrate alarms, empty pipe detection, flow direction or batching
- Adaptive flowrate filter: Integration time programmable 0.1 ... 25.5 seconds  
Filter reset window programmable
- Linearity: 0.1%
- Zero drift: 0.05%
- Temperature drift: 0.015% / °C
- Ambient temperature range: -10 ... +60°C



MX Compact

## Remote Version Mounting Electronics

### MX/M (WALL Mounting)

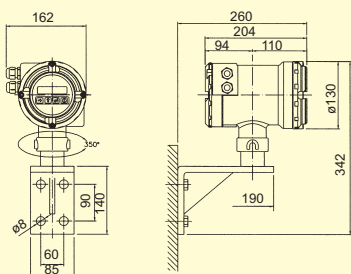

### MX/M (PIPE Mounting)

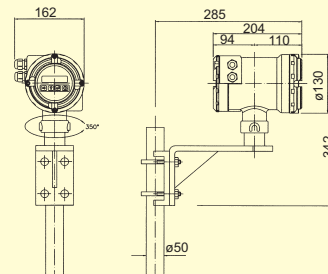

## Series XT5, Electronic Control Units

### Technical Features

- Power supply: 230, 240, 115, 24 Vac 50/60 Hz  
24 VDC
- Power consumption:  $\leq 5$  VA
- Analog output: 4-20 mA. Active or passive
- Pulse output:
  - Opto isolated V max.: 30 Vdc. I max: 30 mA**
  - Maximum frequency in "P/U" mode: 6,25 Hz
  - Maximum frequency in "Hz" mode: 10000 Hz
  - Maximum frequency in "Hz" mode: 0,04 Hz
  - Optional. V max: 240 Vac / 350 Vdc. I max: 100 mA**
  - Maximum frequency in "P/U" mode: 6,25 Hz
  - Maximum frequency in "Hz" mode: 75 Hz
- Totaliser:
  - N° of digits: 7 (2 decimal points)\*\*
  - Digit size: 8 mm
  - Button reset
- Flow indicator:
  - N° of digits 4 (up to 2 decimal point Configuration)\*\*
  - Digit size 5 mm

\*\* When 4 digit counter reaches 10000, 1 decimal point is automatically eliminated.  
When 5 digit counter reaches 10000, the other decimal point is eliminated.

In accordance with Directive 73/23/CEE Low voltage  
In accordance with Directive 89/336/CEE electromagnetic compatibility

### XT5 (Compact model)

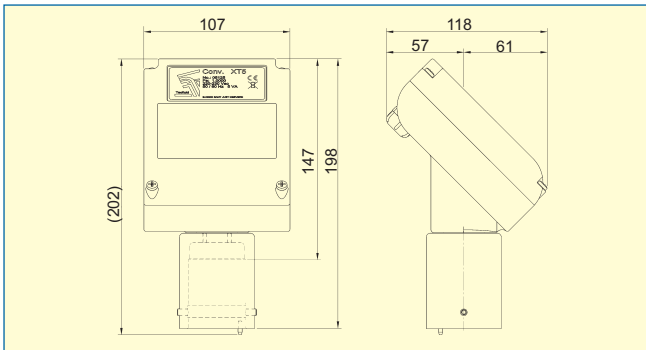

### XT5/M (Wall Mounting)

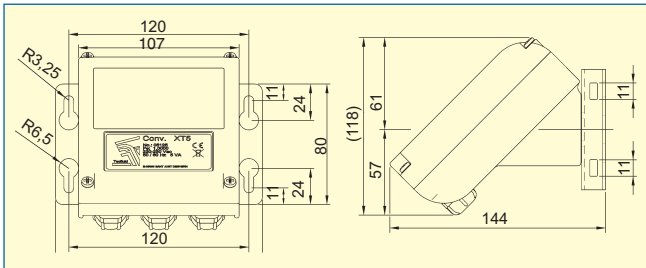

### XT5/M (Pipe Mounting)

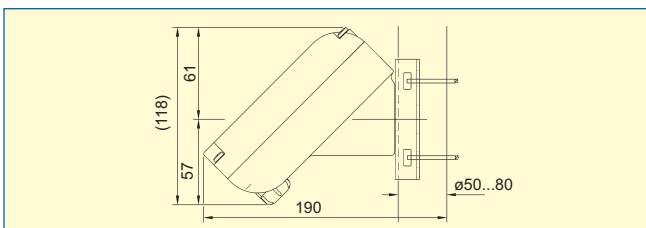

## General Features

- Protection level: IP67
- Ambient temperature range: 0 ... +60°C

## Electrical Features referring to analog loop and Communications

- Reception Impedance: Rx > 8,5 M  $\Omega$  Cx < 200pF
- Models:
  - XT5 compact model
  - XT5/M...T Wall or Pipe mounted
  - XT5H compact model with HART communication
  - XT5HM Wall or Pipe mounted with HART communication

## HART Communication

The XT5H converter has a MODEM for HART communication. You will find all the features regarding HART communication in the corresponding document "Field Device Specification"



## Summary of main communication features

- Manufacturer, Model and revision **Tecfluid S.A., XT5 converter, Rev.0**
- Type of apparatus Transmitter
- HART protocol revision 6.0
- Device description available No
- Number and type of sensors 1, exterior
- Number and type of actuators 0
- Number and type of auxiliary host signals 1, 4 - 20 mA
- Number of Device variables 2
- Number of Dynamic variables 1
- Dynamic Mappables variables No
- Number of Common practice commands 13
- Number of Device specifics commands 8
- Additional Device Status Bits 17
- Alternative function Modes? No
- Burts Mode? No
- Write Protection? Yes

### XT5 Compact



### XT5 Wall & Pipe





# Lloyd's Register España, S.A.

Notified Body N° 0094

## EC CERTIFICATE OF CONFORMITY

In accordance with the requirements of R.D. 769/1999 which transpose the Pressure Equipment Directive 97/23/CE

This is to Certify that the Quality Management System of:

**TECFLUID,S.A.**  
C/ Narcís Monturiol, 33  
08960 Sant Just Desvern  
Barcelona (España)

has been assessed against the requirements of Annex III Module H of the Pressure Equipment Directive 97/23/CE and conforms to the requirements for the product shown below:

**DESIGN AND MANUFACTURING OF FLOWMETERS,  
VOLUMETRIC ACCOUNTANT AND LEVELS**

Approval is subject to the continued maintenance of Quality System in accordance with the requirements of the above Directive and Regulations

Authorisation is hereby given to use the LR Notified Body Identification Number 0094 (Princesa 29, 1ª Madrid - Spain) in accordance with the requirements of specified Directive and Regulations in relation to the products as identified above

Certificate N°: 031

Original Approval: 20/07/2005  
Current Certificate: 20/07/2005  
Certificate Expiry: 31/07/2008



Inserto en el R. M. de Madrid, el 23 de Julio de 2008, a las 17:04. Libro de Inscripciones, folio 115, tomo 1, tomo 1, C.I.F. - A20910287  
Documento Social, C/Princesa 29, 1ª 28008 Madrid

Contacto de la UAB  
P.O. Box 18  
08183 Bellaterra  
P. 34 93 587 20 00  
P. 34 93 587 20 01  
t.c@appluscert.com  
www.appluscert.com  
www.appluscorp.com

Applus<sup>+</sup>  
Certification  
Technological  
Center



# CERTIFICATE

Number **EC-0032/96**

LGA1 Technological Center certifies that the Quality Management System of the supplier:

## TECFLUID, S.A.

C/ Narcís Monturiol, 33  
08960 SANT JUST DESVERN, Barcelona, Spain

for the following activities:

Design, manufacture and after sales service of flowmeters (variable area, orifice plate, target and electromagnetic), volumetric counters and levels,

is in accordance with the requirements of the standard **ISO 9001:2000**



This certificate is valid until March 24, 2006  
Certification del Vallès, March 12, 2004  
Adoption to APPLUS+ Certification Technological Center of the certification dated October 7, 1996

General Director

Manager of the Certification Center

Ramon Capellades i Font

Salvador Boix Iglesias

This certificate shall be valid provided that all the conditions of the contract of which it is a part are fulfilled  
This certificate comes from the EC-0032/96 LGA1 certificate number (20/CV-00002 ENAC Accreditation)



# LABORATORIO OFICIAL J. M. MADARIAGA

- 1.- PRODUCTION QUALITY ASSURANCE NOTIFICATION
- 2.- Annex IV of Directive 94/9/EC.
- 3.- Notification Number: LOM 02ATEX0033
- 4.- MEASUREMENT AND CONTROL ELECTRICAL FOR EXPLOSIVE ATMOSPHERES OF CATEGORY IG.
- 5.- Applicant: TECFLUID, S.A.  
Address: C/ Narcís Monturiol, 33  
08960 SANT JUST DESVERN (Barcelona)
- 6.- Manufacturer: TECFLUID, S.A.  
Address: C/ Narcís Monturiol, 33  
08960 SANT JUST DESVERN (Barcelona)
- 7.- Laboratorio Oficial J. M. Madariaga (LOM) is the Notified Body N° 0163 for Annex IV, in accordance with the Article 9 of the Parliament and Council Directive 94/9/EC of 23 March 1994, notifies to the applicant that the aforementioned manufacturer has a production quality control system which complies to Annex IV of the Directive.
- 8.- This notification is based on audit report N° LOM 02.1311, issued on 2002-06-06.
- 9.- The applicant shall inform Laboratorio Oficial J.M. Madariaga about any relevant modification to the Quality System, particularly concerning to:
  - Person(s) responsible of Quality System and Inspection Controls.
  - Person(s) substituting the Head of Quality Area.
  - Changes the inspection equipment affecting quality controls.
  - Relevant aspects affecting Quality System certification.
- 10.- The applicant is from now monitored by Laboratorio Oficial J. M. Madariaga to verify if the manufacturer duly fulfills the obligations arising out of the approved quality system, as stated in clause 4 of Annex IV of the Directive, and will be surveyed every year.
- 11.- This notification can be withdrawn if the manufacturer no longer satisfies the above mentioned requirements.
- 12.- As stated in article 10 of Directive 94/9/EC, CE marking is accompanied by the identification number of LOM (0163) notified body responsible of surveying the quality of the production.

Madrid, July 9<sup>th</sup> 2002

Cidón Fernández Ramón  
DIRECTOR OF LABORATORY

Ricardo Rodríguez Antón  
Head of Audit Area

(This certificate may only be reproduced on its entirety and without change) Page: 1 / 1



UNIVERSIDAD POLITÉCNICA DE MADRID  
ENAVOS E INVESTIGACIONES DE MATERIAS Y EQUIPOS PARA ATMÓSFERAS EXPLOSIVAS Y HERRAJES  
(Real Decreto 234/1992 de 3 de Abril - BOE 1992-04-29)

MARKETED BY:

Malema Sensors  
Tel: 408-970-3419  
Fax: 408-970-3426  
email: malema@malema.com  
www.malema.com

