



Flow Measurement of Gases & Clear Liquids with Float Series 6001 & 6002.

Measurement Principle

Variable area obtained by the displacement of a float in a conical, Borosilicate glass tube.

Applications

Commonly used in industry to measure the flow for:

- Water treatment.
- Chemical processes.
- Industrial Refrigeration & Air Conditioning.
- Research Laboratories.
- Gas Burners.
- Pilot Plants.
- Annealing Furnaces.

Benefits

- Easy Installation, no straight pipe required.
- Low pressure drop.
- Scaled directly in l/h, l/m, kg/h, %, mm, etc.
- Adjustable alarms, in all scales, operated magnetically or with infra-red light.
- Measuring tube in Borosilicate glass.
- Steel construction, coated with Polyamide 11.
- Connections in Steel, AISI-316, PVC & PTFE.



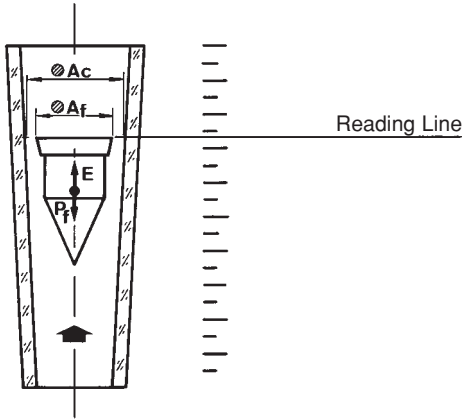

Operation

The fluid flows up through the tapered tube forcing the float to a position with sufficient free area to enable the flow to pass. This free area is related to the flow rate, the weight of the float and the density and viscosity of the fluid.

The pressure drop across the flow meter remains constant over the entire flow range. This occurs because the pressure drop is related to the fluid velocity and area of flow, the area of flow increases as the flow rate increases.

Technical Data

- Connections:
 - 6001 threaded 1/2" to 3" BSP
 - 6002 flanged DN-15 to DN-80, PN-16.
 - ASA, BST, 11851 (sanitary) available as specials.
- Length

	Minimum	Maximum
6001	410mm	510mm
6002	380mm	420mm
- Accuracy:
 - According to standards VDI/VDE 3513 Class 1.6
- Scales graduated in l/h, l/min, kg/h, %, mm, etc
 - Scale length 200mm $\pm 10\%$
- Rangeability 10:1
- Operating Temperature
 - Resistant to thermal shock to 180°C
 - Recommended Maximum Differential Temp 100°C
 - Operating Variation 70-80°C
- Materials

Series	Body /Protection	Float
6001-6002	Coated Steel	AISI-316
600../SS	AISI-316	AISI-316
600../PVC	PVC	AISI-316/PVC + Lead
600../PTFE	PTFE	AISI-316/PTFE + Lead
- Alarm Options:
 - 60-AMM 1...2 Magnetic Actuated micro switch.
 - 60-AMD 1...2 Inductive proximity sensor.
 - 60-AMO 1...2 Optical position detector.
 - 60-AMR 1...2 Magnetic actuated reed switch.

TYPE AC

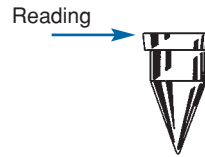

TYPE ECG



As standard, the floats are made from AISI-316, PVC-Lead, PTFE-Lead for use in liquids, and Aluminium, PVC, PTFE for use with gases.

Other materials, also available when necessary to suit different fluids.

Series 6001

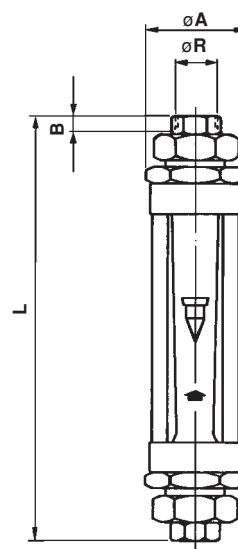

Series 6002

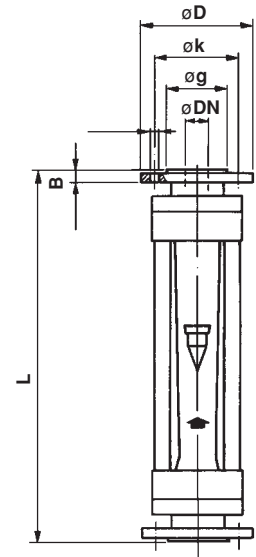

Series 6001

R"	DN	A	B	L	Wt, kg
1/2	15	60	15	410	1.8
3/4	20	60	15	415	2.2
1	25	75	20	425	3.3
1 1/2	40	105	20	445	5.9
2	50	120	25	460	9.6
2 1/2	65	150	25	505	12.5
3	80	150	30	510	16.5

Series 6002

DN	D	k	g	B	1xno	L	Wt, kg
15	95	65	45	14	14x4	380	2.5
20	105	75	58	14	14x4	380	3.3
25	115	85	68	16	14x4	390	4.8
40	150	110	88	16	18x4	400	8
50	165	125	102	18	18x4	410	11
65	185	145	122	18	18x4	420	15.3
80	200	160	138	20	18x4	420	19.3

Variable Area Flowmeters 6001/6002

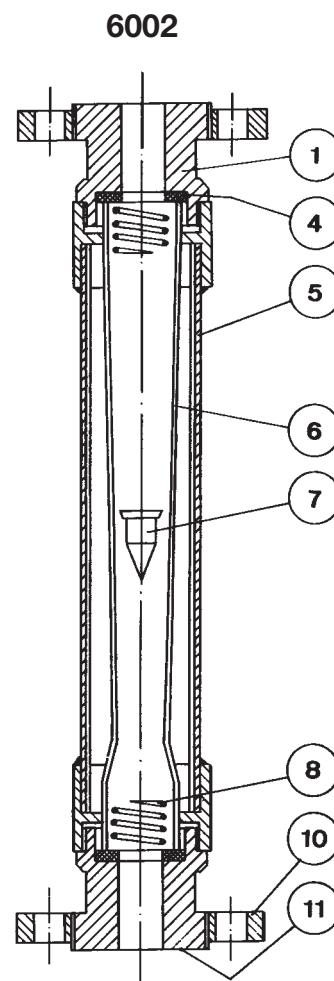
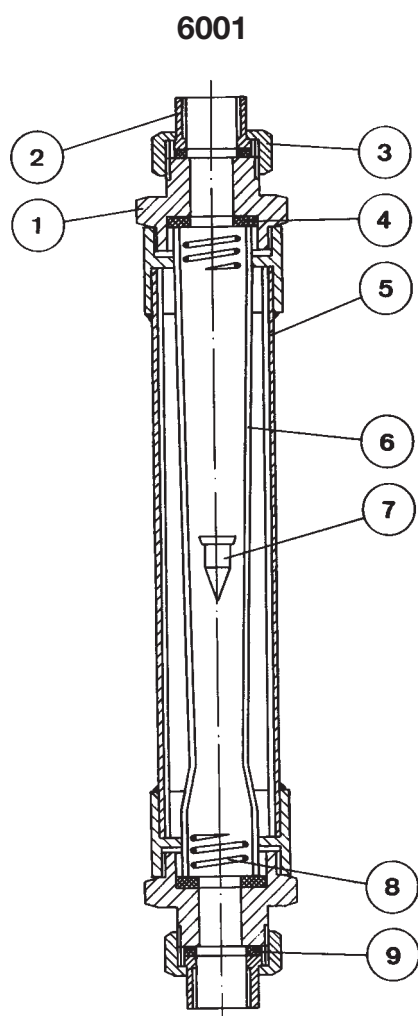

n°	Item	Materials			
		6001 6002	6001-SS 6002-SS	6001-PVC 6002-PVC	6001-PTFE 6002-PTFE
1	End piece	Steel	AISI-316	PVC	PTFE
2	Connector	Steel	AISI-316	PVC	PTFE
3	Nut	Steel	AISI-316	PVC	PTFE
4	Seal	Nitrile	Nitrile	Nitrile	Nitrile
5	Frame	Coated Steel*	Coated Steel*	Coated Steel*	Coated Steel*
6	Flow Tube	Borosilicate Glass	Borosilicate Glass	Borosilicate Glass	Borosilicate Glass
7	Float	AISI-316/Aluminium	AISI-316	PVC	PTFE
8	Spring	AISI-316	AISI-316	PVC	PTFE
9	Connector Seal	Nitrile	Nitrile	Nitrile	Nitrile
10	Flange	Steel	Steel/AISI-316	Steel/PVC	Steel/PTFE
11	Flange Neck	Steel	AISI-316	PVC	PTFE

* Frame also in AISI-316 on order



Metering Tube Series C	Measuring Range for Float Type AC 						Max. Pressure Bars	Pressure Drop mm Water		Tube Length mm (±1mm)	Series 6001 6002	
	AISI-316 7.95 g/cm ³			ALUMINIUM 2,85g/cm ³				FLOAT			R" DN	
	Water 20° C l/h		Air @ STP Nm ³ /h		Air @ STP Nm ³ /h			AISI-316	ALUM.			
	min	max	min	max	min	max						
C311-0025	2.5	25	0.07	0.7	0.04	0.4	15	55	22	300	1/2" DN-15	
C311-0040	4	40	0.11	1.1	0.07	0.7	15	55	22	300		
C311-0060	6	60	0.18	1.8	0.10	1	15	55	22	300		
<hr/>												
C312-0100	10	100	0.30	3	0.17	1.7	15	90	35	300	1/2" DN-15	
C312-0160	16	160	0.45	4.5	0.25	2.5	15	90	35	300	3/4" DN-20	
C312-0250	25	250	0.7	7	0.4	4	15	90	35	300		
<hr/>												
C313-0400	40	400	1.1	11	0.7	7	15	125	50	300	3/4" DN-20	
C313-0630	60	630	1.8	8	1	10	15	125	50	300		
C313-1000	100	1000	3	30	1.7	17	15	125	50	300	1" DN-25	
<hr/>												
C314-1600	160	1600	4.5	45	2.5	25	10	175	75	300	1 1/2" DN-40	
C314-2500	250	2500	7	70	4	40	10	175	75	300		
<hr/>												
C315-4000	400	4000	11	110	7	70	8	230	95	300		
C315-6300	500	6300	18	180	10	100	8	230	95	300		
<hr/>												
C316-M010	1000	10000	30	300	17	170	6	300	125	300	2" DN-50	
C316-M014	2000	14000	120	420	45	200	6	300	125	300		
<hr/>												
C317-M016	1600	16000	45	450	25	250	5	400	170	300	2 1/2" DN-65	
C317-M020	2500	25000	70	700	40	400	5	400	170	300		
C317-M030	3000	30000	90	900	50	500	5	400	170	300	3" DN-80	
C317-M040	6000	40000	180	1200	100	712	5	400	170	300		

Metering Tube Series CG	Measuring Range for Float Type ECG 									Max Pressure Bars	Pressure Drop mm Water		Tube Length mm (±1mm)	Series 6001 6002	
	AISI-316 7.95 g/cm ³			GLASS 2.6 g/cm ³			PLASTIC				Float			R" DN	
	Water 20°C l/h		Air @ STP NI/h		Water 20°C l/h		Air @ STP NI/h		Air @ STP NI/h		AISI-316	Glass			
	min	max	min	max	min	max	min	max	min		max				
C301-0008	0.8	8	24	240	0.2	2	15	150	5	50	20	20	10	300	1/2" DN-15
C301-0016	1.6	16	40	400	0.5	5	30	300	10	100	20	20	10	300	
C301-0025	2.5	25	120	1200	1	10	40	400	20	200	20	20	10	300	
C301-0040	4	40	160	1600	1.6	16	70	700	30	300	20	30	12	300	

Equivalent flow curves for liquids with a different density or viscosity to water

FLOW /h

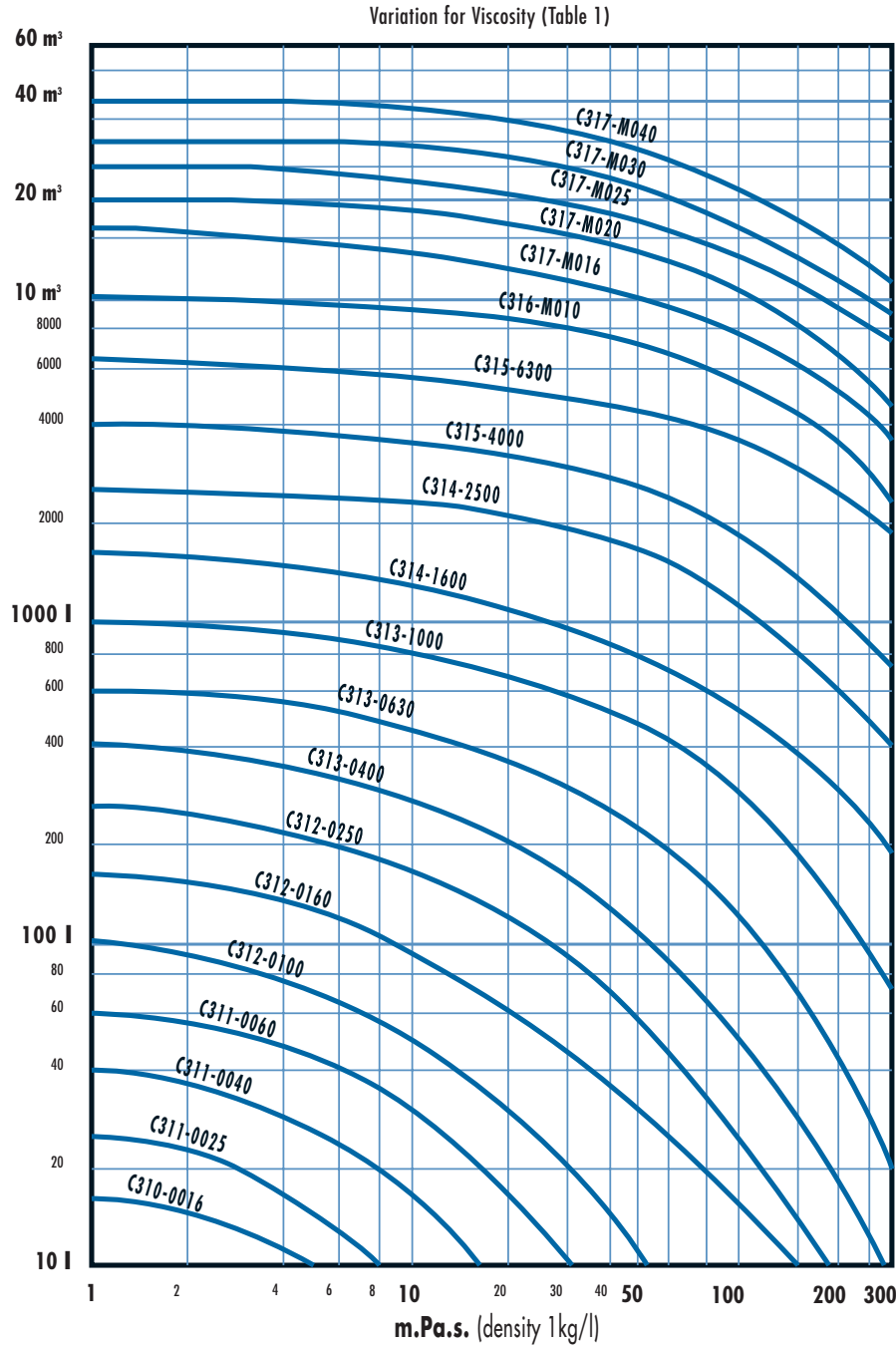

FLOW /h

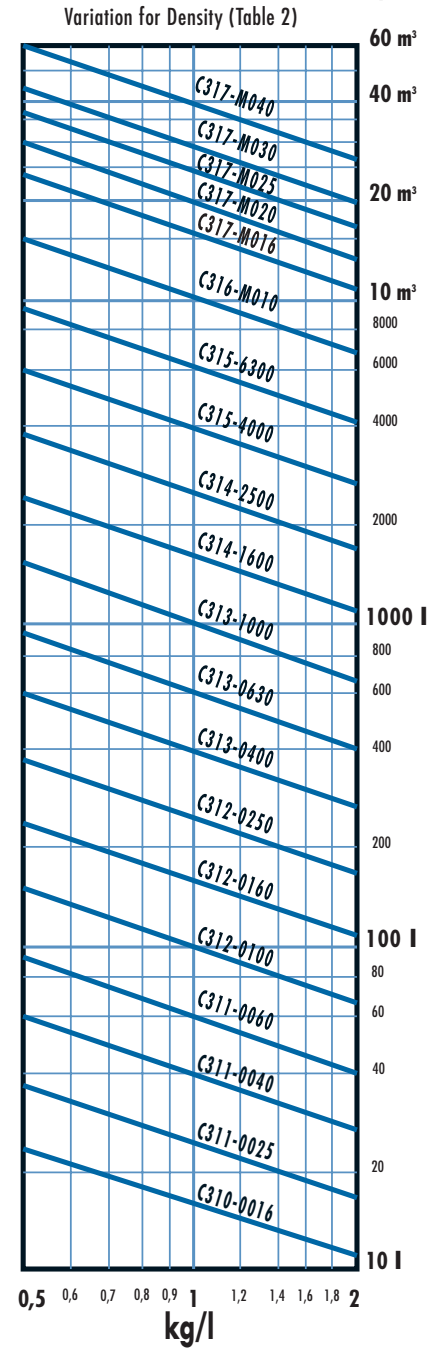

Examples:

No. 1 Variation for Viscosity (Table 1)

Flow 1000l/h, viscosity 50mPas. Enter the graph at the viscosity value and travel vertically to the point where it cuts the horizontal line at 1000l/h. This point determines the tube selection and if it coincides with one of the curves, it is the value of maximum flow. If the point lies between two curves, it is optional to select either the upper or lower. The lower (C314-1600) will provide a maximum flow of 800l/h and the upper (C314-2500) will provide a maximum flow of 1800l/h.

No. 2 Variation for Density (Table 2)

Flow 1000l/h, density 1.4kg/l. Enter the graph at the 1000l/h point. Move horizontally across to applicable flow tube line (C313-1000), travel the inclined line to the point of the density of the fluid (1.4kg/l). Travel horizontally to the vertical axis and read the equivalent flow scale 800l/h.

No. 3 Variation for Viscosity and Density

First, follow the steps in example 1, then follow the steps in example 2.



Alarms

AMM/AMR/AMD

R	DN	A	B
1/2"	15	-	-
3/4"	20	132	45
1"	25	132	45
1 1/2"	65	175	45
3"	80	175	45

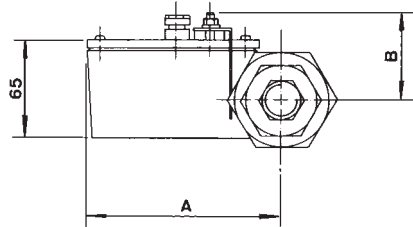
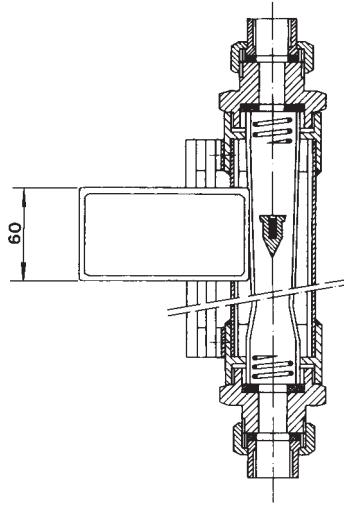

AMO

R	DN
1/2"	15
3/4"	20

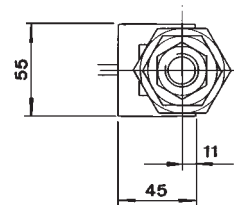
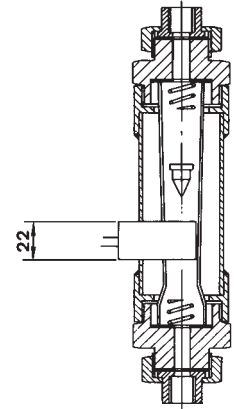

Adjustable Alarm 60-AMM

(from 40-400 l/h Water & 0.7-7 Nm³/h Air)

Micro-switch contact, mounted in an aluminium enclosure, actuated by a magnetic field from the float.

- 60-AMM1...2: 1...2 adjustable alarm contacts.
- Power Supply: 220Vac (6A), 24Vdc (0.5A).
- Load: 6 Amp @ 220Vac/50Hz.
- Temperature: -25°C to +80°C.
- Hysteresis: ±10% of full scale.
- Mechanical life: 20 x 10⁶ Operations.
- Contact speed: 0.01 to 1 mSec.

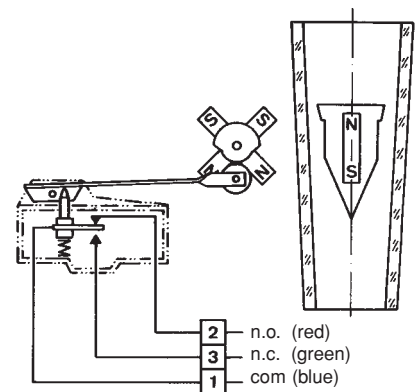

Adjustable Alarm 60-AMD

(from 40-400 l/h Water & 0.7-7 Nm³/h Air)

Adjustable Inductive Alarm, based on plate & gap detection with 3.5mm NAMUR (DIN 19234), mounted in an aluminium enclosure, actuated by a magnetic field from the float.

- 60-AMD 1...2: 1 ... 2 adjustable alarm contacts. (+ amplifier WE77/Ex1 or Ex2).
- Power Supply: 8 Vdc.
- Temperature: -25°C to + 70°C.

Control Relay:

Model WE77/Ex 1...2: for 1 or 2 inductive alarms.

- Power Supply: 220VAC \pm 15%, 50-60Hz. (Also available in other voltages for AC & DC).
- Control circuit is intrinsically safe to EEx ia II C (Zone 0).
- Load: 4 Amps @ 250VAC/250 VA.
- Temperature: -25°C to + 70°C.

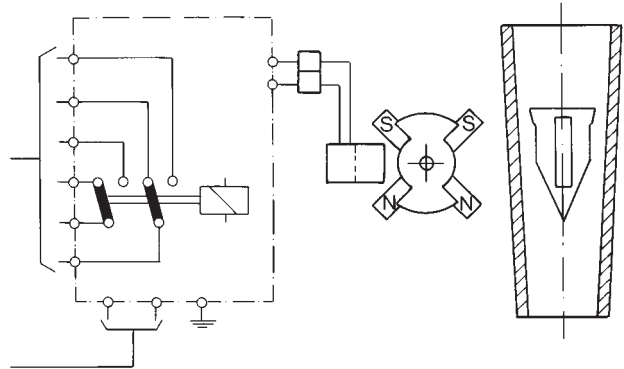

Optical Alarm, Series 60-AMO

(from 25-250 l/h Water & 0.4-4 Nm³/h Air)

Optical contact, in infra-red light, actuated by interruption of the beam with the float. Mounted in a PVC support, with the relay in a separate aluminium enclosure. The cable length between the control relay and sensor is 1,5 m.

- 60-AMO 1...2: 1 or 2 adjustable alarm contacts.
- Power Supply: 220Vac/50Hz or 24Vdc.
- Load: 1 Amp @ 220Vac/50Hz.
- Temperature: -10°C to + 50°C.
- Hysteresis: \pm 5% of full scale

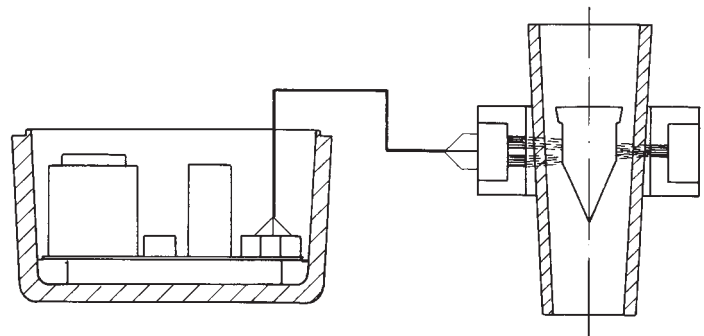

Adjustable Alarm 60-AMR with REED

(from 40-400 l/h Water & 0.7-7 Nm³/h Air)

Reed switch contact, mounted in an aluminium enclosure, actuated by a magnetic field from the float.

- 60-AMR 1...2: 1...2 adjustable alarm contacts.
- Power Supply: 220Vac (1A), 24Vdc (1A).
- Load: 1 Amp @ 220Vac/50Hz.
- Temperature: -15°C to + 60°C.
- Hysteresis: \pm 5% of full scale.

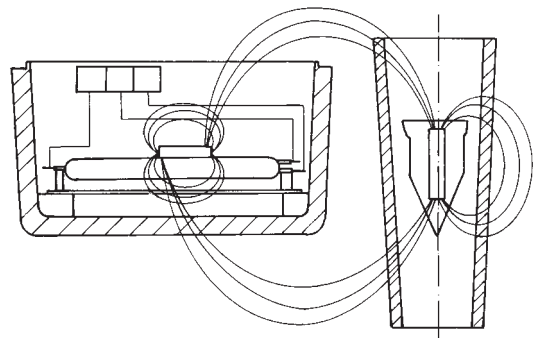



Analog Transmitter 60 / TMUR 0...4-20 mA (From 40-400 l/h water and 0.7-7 Nm³/h air)

Electric analog transmitter using a reed chain mounted in a plastic housing which screws onto flowmeter main body.
Separate electronics mounted in a DIN 46277 rail mounting plastic case (IP 40).

- Power Supply: 220V, 110V, 24V 50-60 Hz or 24 Vdc
- Output Signal: 0-20 mA, 4-20 mA, 0-5 V, 0-10 V
- Connection: 4 wire
- Number of Steps: 20 maximum for full output range
- Precision: $\pm 7\%$ of full scale reading

DN	A
15 - 20	80
20 - 25	85
40	101
50	107
65 - 80	120

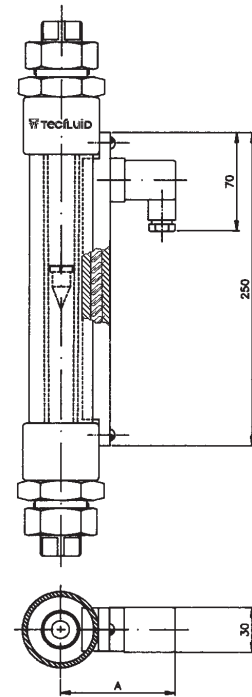

We are at your service, please consult us.
TECFLUID develops and manufactures instruments for gases and liquids, using the most advanced techniques.

FLOWMETERS

- Variable area with Glass metering tubes.
- Variable area with Metal metering tubes, and indication via magnetic transmission.
- Target disk and indication via magnetic transmission.
- Orifice disk.
- Electromagnetic.

In preparation:

- VORTEK

COUNTERS

- COVOL (Oscillating piston)
- TM-44 (Turbine)

LEVELS

- Limit switches
- Indicators
- Transmitters

ELECTRONIC EQUIPMENT

- Converters
- Batching Counters
- Flow rate indicators
- Transmitters

Request Information by telephone n° (34 3) 372 45 11

Marketed by:

Malema Sensors
1060 S.Rogers Circle
Boca Raton, FL 33487
U.S.A
Tel: 1-561-995-0595, Fax: 1-561-995-0595
email: IndustrialSales@malema.com
URL: www.malema.com

