

OUTLINE

Our clamp-on type ultrasonic flowmeter **UL320** is "time-flight type" flowmeter and capable of measuring a flow rate of metallic and plastic piping ranging from 25 to 1,000 mm in nominal diameter. The ultrasonic sensor is mounted to the exterior of an existing piping by clamping method so that it will not come into contact with the measuring fluid at all. It is capable of measuring a flow rate without considering corrosion of the sensor due to a corrosive fluid, particle/metallic ion contamination by the moving part of the flowmeter, and pressure loss.

FEATURES

- Combined use of a DSP and an AD converter speeds up flow rate measurement (higher-speed zero-cross measurement) to improve bubble resistance and provide high-accuracy measurement in small flow rate.
- A complete non-contact measuring method perfectly prevents generation of particles and mixture of metallic ion.
- Installation of the flowmeter does not cause pressure loss because the sensor has no obstacles in the measuring pipe.
- The ultrasonic flowmeter is not affected by the pressure or conductivity of a fluid.
- Superior long-term stability because there are no moving parts.
- Standard functions include forward/backward flow rate display, totalizing display, analog output, pulse output, status output (various alarms: selective), and flow direction output.
- Capable of controlling a flow rate with digital data by adding an optional function, RS-485 serial output. (Forward/backward flow rate output, totalizing output, and status output by the Modbus protocol) A multi-drop connecting method greatly reduces signal wires.
- CE marking (Pending) and lead-free

MEASURING PRINCIPLE

As shown in Fig.1 the ultrasonic is transferred from A to B and B to A in turn with an angle of ψ . The required duration of transfer of two directions is different when measuring medium is moving from upstream to downstream. The duration of transfer is expressed by the following formula.

$$t_{AB} = 2L / (C_0 + V_m \cos \psi)$$

$$t_{BA} = 2L / (C_0 - V_m \cos \psi)$$

Where

- 2L: Distance between A and B
 V_m : Average velocity of medium
 C_0 : Sonic speed in stable medium
 t_{AB} , t_{BA} : Duration of transfer of Ultrasonic from A to B and B to A



By measuring the difference of the transfer duration, the average velocity of medium can be calculated. The calculation is done by the following formula:

$$2V_m \cos \psi = 2L / t_{AB} - 2L / t_{BA}$$

$$= 2L (t_{BA} - t_{AB}) / (t_{BA} \times t_{AB})$$

$$V_m = L (t_{BA} - t_{AB}) / (\cos \psi \times t_{BA} \times t_{AB})$$

The distance between A and B (L) and the angle (ψ) are known, and the average velocity is mathematically calculated.

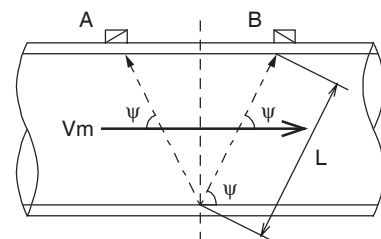

Fig. 1

STANDARD SPECIFICATION

- Measuring method : Ultrasonic time-flight type (Ultrasonic path Reflex mode/ V path or Diagonal mode/ Z path)
- Construction : Sensor, Converter, Exclusive coaxial cable with BNC connector, and Sensor fixing rail)
- Sensor mounting : Piping clamp-on type
- Measuring fluid : Liquids which can be penetrated with ultrasonic waves (Not suitable for liquids containing many bubbles and slurry and high viscosity liquids).
- Measurable fluid ultrasonic range (viscosity) : 1,000 to 2,500 m/s (0.30 to 40.00 mm²/s)
- Fluid temperature : Up to 90°C (Piping surface temperature)
- Measurable piping materials : SGP, Stainless steel, PVC, PVDF, PP, and PE (Materials which can be penetrated with ultrasonic waves.)
- Measurable nominal piping diameter : 25mm (Min.) to 1,000mm (Max.) (Refer to Table 1 for sensor selection and its mounting method)
- Measurable flow velocity range : 0.3 m/s (At minimum settable full scale flow rate)
10 m/s (At maximum settable full scale flow rate)
- Accuracy : At flow velocity of 1 m/s or more; Reynolds number Re = 10,000 or more, Indication value +/- 2.0%
At flow velocity of less than 1 m/s; Flow velocity error = +/- 2 cm/s
- Display : 16-digit, 2-line alphanumeric LCD (with backlight) and status display LEDs (3 pieces)
Display data : Flow rate, totalizing flow rate, various status, forward and backward flow directions
- Power supply : AC type; 100 to 240 V AC, 50/60 Hz (Operating voltage range: 85 to 264 V AC, 50/60 Hz),
- Power consumption : AC type; 10 VA or less,
- Cable entry : For power/output (M20 x 1.5, 3 pieces); With waterproof cable gland (Applicable cable diameter: ø8.0 to ø13.0)
For sensor; Waterproof BNC connector (2 pieces)

- Outputs
 - 1) Analog output : 4 to 20 mA DC or 0 to 20 mA DC (Selective), Load resistance: 500Ω or less
 - 2) Pulse output : Open collector output: Load rating: 30 V DC, 50mA
Pulse width: 0.5 ms/1000PPS, 0.5ms/100PPS, 50ms/ 10PPS, 500ms/1pps, 1000ms 0.5PPS (Selective)
 - 3) Status output : Status 1/2: 2 kinds selectable out of Flow rate alarm H, Flow rate alarm L, Preset A, Preset B, and Error alarm
Status 3: Flow direction (fixed)
Common to Status 1 to 3: Open collector, Load resistance : 30 V DC, 50 mA, Operation mode : NO/NC (Selective)
 - 4) Serial output : RS-485 serial output (option), Modbus protocol
Transmission speed/distance — 2,400, 4,800, 9,600 or 19,200 PPS, 1.2 km (Max. total distance at the time of multi-drop connection)
Slave addresses: 1 to 31, Hard (DIP) setting (optionally settable)
* For details of a data format, consult our factory.
- Damping setting : 0 to 100 s (Settable in increments of 1s step)
* Valid for display, analog output and pulse output.
There is a response delay of 0.1 s, even if damping is set to 0 s.
- Low cutoff setting : 0 to 30% of the maximum flow rate (Settable in increments of 1%)
* Valid for display, analog output and pulse output.
- Parameter setting : Set with the key switches on the converter's front panel.
- Other additional functions
 - 1) Analog and pulse simulation output function (For loop check)
 - 2) Forward/backward direction measuring function
- Painting of converter : Epoxy resin painting (Blue/Light gray)
- Converter mounting method : Mounted onto the wall or 2B pipe
- Enclosure : Converter / IP65 Jet-proof,
Sensor / IP65 Jet-proof (BNC connector guaranteed in the coupled condition)
- Material : Sensor housing / ABS
Sensor mounting rail / Aluminum
Converter housing / Aluminum alloy
- Converter ambient temperature and humidity : -20 to 50°C, 10 to 90% RH (No dew condensation)
- Sensor signal cable : Standard 10 m (Up to 60 m)

Table 1. Sensor choice table

Pipe material	Nominal pipe size (D)	Sensor installation	Sensor rail length	Support rail	Code of sensor combination
Resin (PVC • PE etc.)	25A ≤ D ≤ 50A	V	320 × 1 pc	320 × 1 pc	1
	65A ≤ D ≤ 150A	V	320 × 1 pc	Not provided	2
	200A ≤ D ≤ 450A	V	620 × 1 pc	Not provided	3
	500A ≤ D ≤ 1000A	Z	620 × 2 pcs	Not provided	4
Resin (PVDF • PP etc.)	25A ≤ D ≤ 50A	V	320 × 1 pc	320 × 1 pc	1
	65A ≤ D ≤ 150A	V	320 × 1 pc	Not provided	2
	200A ≤ D ≤ 400A	V	620 × 1 pc	Not provided	3
Metal	25A ≤ D ≤ 150A	V	320 × 1 pc	Not provided	2
	200A ≤ D ≤ 450A	V	620 × 1 pc	Not provided	3
	500A ≤ D ≤ 1000A	Z	620 × 2 pcs	Not provided	4

Note 1.: For unspecified resin piping, consult our factory.

Note 2.: Metallic piping materials are stainless steel. (For schedule 80 or above, consult our factory in advance)

Note 3.: The sensor mounting method V path to the reflex mode and Z path to the Diagonal mode.

Note 4.: If the installed piping nominal diameter is unknown (100mm or more) or if the mounting piping may be changed, select Sensor Rails Length "620 mm × 1 pc or 620 mm × 2 pcs" Type: Combination code.

Note 5.: A reinforcement rail is used for the resin piping whose nominal diameter is 50mm or less.

Note 6. Refer to MODEL CODE.

DIMENSIONS

CONVERTER

- Wall mount type

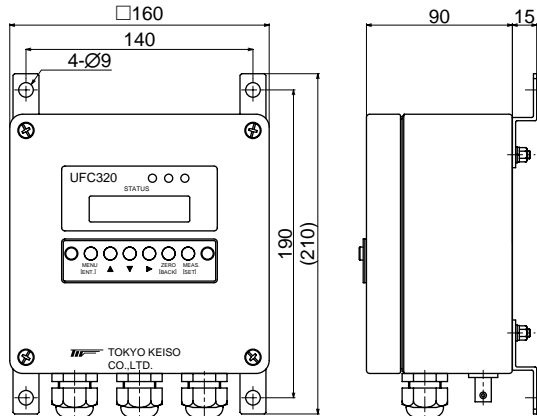

- 2" pipe mount

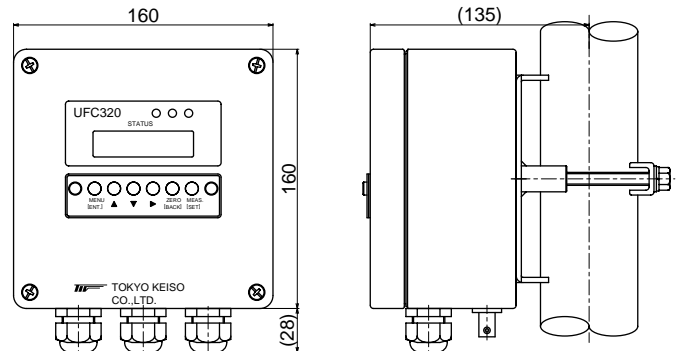

SENSOR

- Reflex mode (V path: Nominal diameter D: 25A ≤ D ≤ 450A)

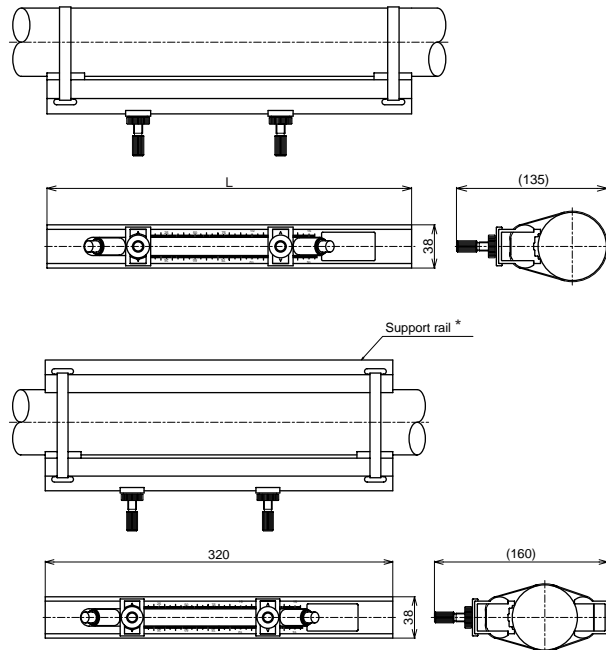

- Diagonal mode (Z path: Nominal diameter D: 500A ≤ D)

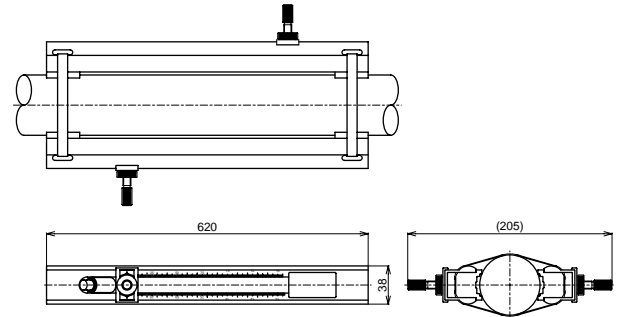

*Reflex mode (V path) Rail length

Nominal pipe size: D (mm)	L (mm)
25A ≤ D ≤ 150A	320mm
200A ≤ D ≤ 450A	620mm

*Support rail is to be used for the resin pipe from 25 to 50mm.

FLOW RATE RANGE/SIZE

Nominal diameter (mm)	Possible scale range (m³/h)	
	Minimum	Maximum
25	0.684	22.80
32	1.167	38.91
40	1.568	52.27
50	2.556	85.21
65	4.192	139.7
80	5.857	195.2
100	9.948	331.6
125	15.00	500.1
150	21.28	709.4
200	36.80	1226
250	57.07	1902
300	81.25	2708
350	101.3	3377
400	133.2	4442
500	209.5	6984
600	0.301(km³/h)	10.06(km³/h)
700	0.409(km³/h)	13.66(km³/h)
800	0.538(km³/h)	17.95(km³/h)
900	0.684(km³/h)	22.82(km³/h)
1000	0.843(km³/h)	28.10(km³/h)

[Note] The above-mentioned flow rates have been calculated for the SUS Sch. 10s pipes, at the minimum range flow velocity of 0.3 m/s and maximum range flow velocity of 10 m/s. (The flow rate range may differ slightly, depending on the piping standard.)

ELECTRICAL CONNECTION

TB1(3P)			TB2(10P)							TB3(3P)		
Power supply (AC)			Analog output DC4 to 20mA	Pulse output	External totalization reset	Status output			Serial output RS-485 (Option)			
(3P)						Status 1	Status 2	com		Status 3		
L1	L2	G	(2P)	(2P)	(2P)	(4P)			(3P)			
+	-		① ②	③ ④	⑤ ⑥	⑦ ⑧	⑨ ⑩	⑪ ⑫	⑬ SG			
			+ -	+ -	+ -	+ +	+ +	com +	+ -			

Note: The AC type does not have the polarities L1 and L2.

Note: For Status 1 and 2, you may select two out of flow rate alarms H and L, presets A and B, and error alarm. Status 3 is for flow direction (fixed).

MODEL CODE

• Sensor

Model code					Description
UFS320	A				
Sensor combination		1			Short sensor rail × 1 pc, Support rail × 1 pc
		2			Short sensor rail × 1 pc
		3			Long sensor rail × 1 pc
		4			Long sensor rail × 2 pcs
Cable length		1			10m (Standard)
		2			20m
		3			30m
		4			40m
		5			50m
		6			60m
Additional functions		(Blank)			NA
		/Z			Provided

• Converter

Converter Model code					Description
UFC320	A				
Power supply	A				100 to 240 V AC 50/60Hz
	-				
Mounting		1			Wall mount type
		2			2" pipe mount type
Serial output		1			Standard
		2			Modbus specification (With serial output RS-485)
Additional functions		(Blank)			NA
		/Z			Provided

PRECAUTION FOR USE

- * To ensure accurate flow rate measurement, straight pipes are required in the upstream and downstream of the sensor mounting position. (Generally, 10D or more on the upstream side and 5D or more on the downstream side; D = nominal piping diameter), (For details, refer to the Instruction manual or JEMIS-032)
- * Mount the sensor to the piping which is always filled with liquid. When used for a liquid containing bubbles, mount it to the position where they do not stay in the piping.
- * Except a ball valve (reduced type excluded) or gate valve used in the fully closed condition, mount to the downstream side of the sensor.
- * When installing outdoors for use, it is recommended to attach a waterproof cover to the sensor in order to prevent deterioration of sensor grease.

Marketed by:

Malema Sensors
 1060 S.Rogers Circle
 Boca Raton, FL 33487
 U.S.A
 Tel: 1-561-995-0595, Fax: 1-561-995-0595
 email: industrialsales@malema.com
 URL: www.malema.com

* Specification is subject to change without notice.

