

Inline Ultrasonic Flowmeter



The M-1500 series is an inline primary flow sensor and externally mounted controller unit. The flow sensor is a straight through flow tube that uses “Transit Time” differential method with a microprocessor based measurement design for precise measurement of flow rate. The controller electronics receives the raw flow rate signal from the sensor and provides flow rate information in terms of analog and pulse output signals.

Operation

This flowmeter uses a non-intrusive method to determine the flow rate of the liquid. Two piezoelectric transducers are mounted on the outer diameter of the flow tube and are excited producing a vibration. Alternately each transducer’s ultrasonic disturbance transmits through the tubing wall and is propagated along with the liquid flow and back against the flow. The propagation wave velocity varies with flow rate and is proportional to flow rate. The flow rate can be determined by measuring the variation of these propagation wave velocities. (Covered by U.S. Patents)

Applications

- CVD, CMP, and lithography tools
- Medical Devices
- Wet process systems
- Corrosive chemical distribution
- Laser equipment
- Cooling systems

M-1500 Series

Installation and Operating Manual

Features

- Ultrasonic flow sensing technology - robust proven technology
- Capable of measuring flows from 1 - 4000 ml/min
- Measuring accuracy of $\pm 2\%$ of READING (5% of reading below 20% of flow range)
- Compact design - ideal for use in semiconductor process tools
- Sensors/Transducers sit outside tube - hence completely non-invasive
- No pressure drop - since there is no obstruction in flow path
- Minimal bubble entrapment compared to other designs due to INLINE flow path
- Ideal for precise measurements in low flow applications
- No moving parts: hence no particle generation
- Fast response time (0.1 sec) ideal for CMP process measurements where flow fluctuations are high due to use of peristaltic pumps
- Transducers resistant to harsh chemical environments (NEMA 4X compliance)

Certifications

Applied for UL and CE certificates.

Dimensions

SENSOR DIMENSIONS

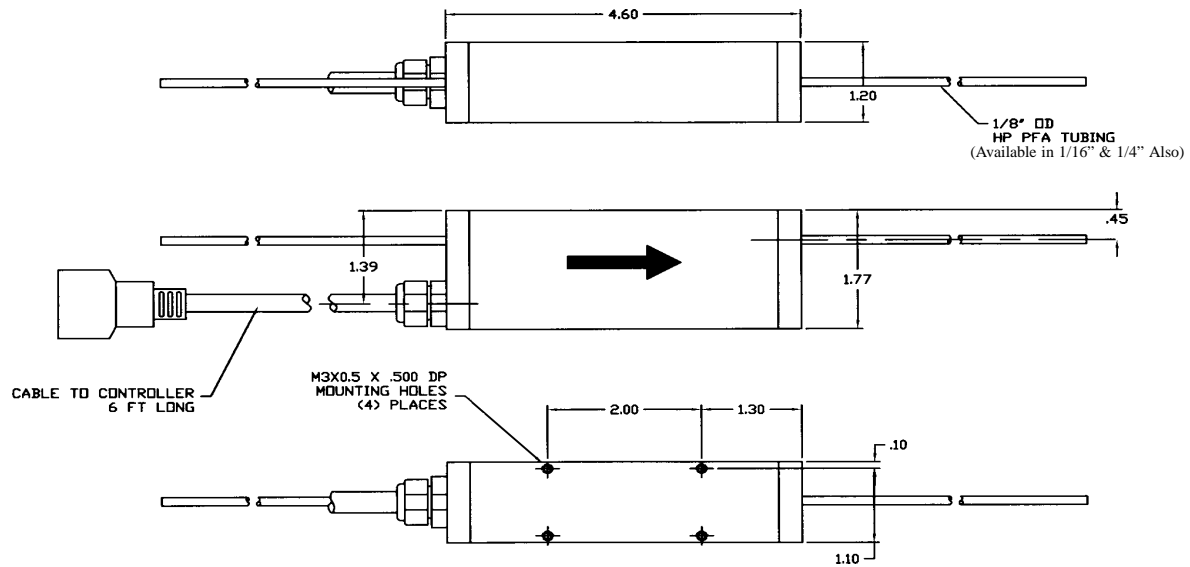

DIMENSIONS FOR SINGLE CONTROLLER

Figure 1

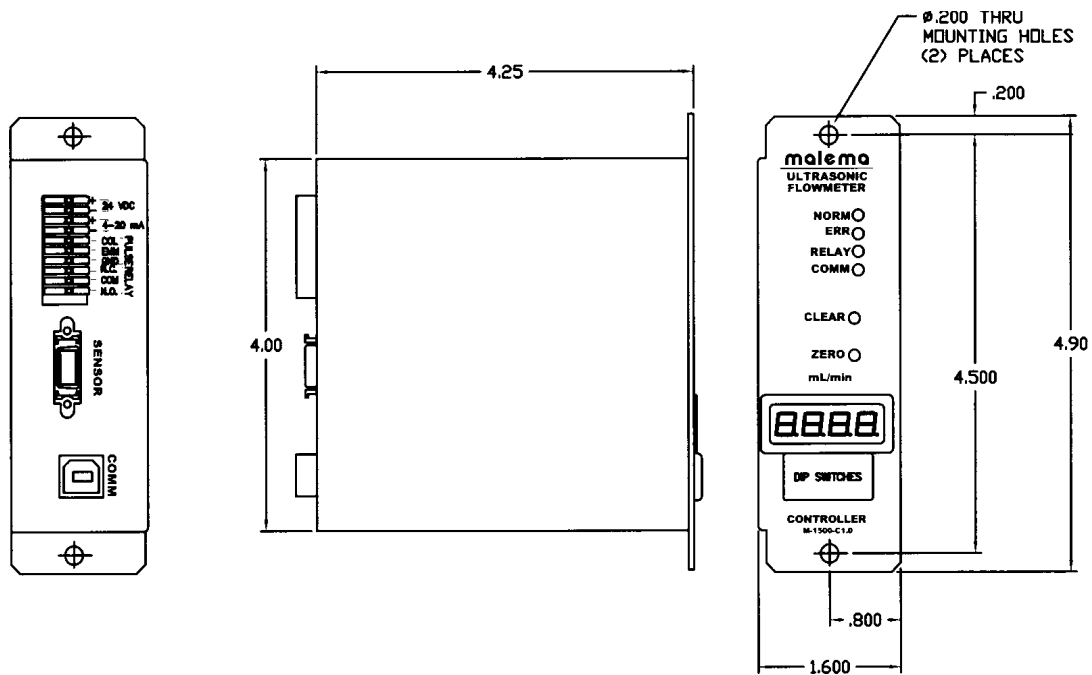

Figure 2

Inline Ultrasonic Flowmeter

Specifications

Performance Specifications

Flow Range: 1 - 4000 ml/min
Accuracy: $\pm 2\%$ of reading
(for 20 - 100% of flow range)
 $\pm 5\%$ of reading for 0 - 20%
of flow range.
Repeatability: $\pm 0.5\%$

Functional Specifications

Analog Output: Isolated 4-20 mA (Maximum load
resistance of 500 ohm) current
output.
Pulse Output: Isolated Open Collector (15V, 15 mA)
Frequency of 1000 hz at flow rate
of 100%
Low flow cut off: 2% - Enabled by Dip Switch
Electrical Input: 24 VDC $\pm 10\%$
300mA
Optional Display: 4 digit 7 segment display, indicates
instantaneous flow rate in ml/min
Ambient Temperature range: 32 - 115 F (0 - 46 deg C)
Fluid Temperature range: 50 - 140 F (10 - 60 deg C)
Maximum Operating Pressure: 70 psig for PFA
Cable Material: PTFE Jacketed Custom
shielded cable.
Cable Length: 3 Meters max.
Fluid Viscosity: 8 cP max.¹
Time Constant: Field Adjustable(0.1s to 5s)

¹ Higher viscosities would require special tube sizing and
custom calibration.

Material Specifications

Sensor Housing : PP or PTFE or PVDF
Non-wetted parts: Peek, PP, PVDF, VitonA, FEP
Wetted parts: PFA (high purity)

Physical Specifications

Sensor unit: Equivalent to NEMA 4X(IP65)
Controller: Equivalent to NEMA 2 (IP20)
Sensor Unit Dimensions : 1.3" (W) X 2.0" (H) X 4.4" (D)
Single Controller Dimensions :4.0" (W) X 1.65" (H) X 4.3" (D)

Installation

Sensor

Select location for mounting sensor that has

- Ambient temperature (0 to 60°C (32 to 140 F) away from direct sunlight.
- Free from electromagnetic interference. Keep away from heavy electrical devices such as motors, pumps, power-relays and solenoid valves.
- No air or gas bubbles in the flow, since they cause hindrances to propagation of ultrasonic waves.
- No water splashes or corrosive gases.
- Has ease of access for maintenance.

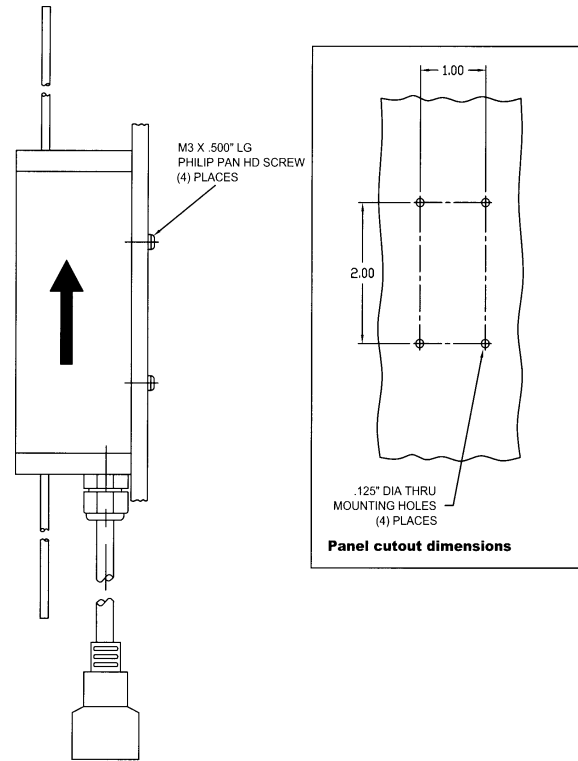

SENSOR MOUNTING DETAIL

Figure 3

Mounting Hardware: Use four M4 x X (X = 0.35" + thickness of the mounting plate) Philip pan head screw (not provided) to secure the M-1500 sensor onto the panel.

It is advisable to mount the flow sensor with the flow going vertically upward. This ensures that no bubbles get trapped within the sensor. This also prevents any sedimentation from the fluid from accumulating inside the sensor section.

It is advisable to mount the sensor at a position in the flow circuit that has maximum fluid pressure (upstream of flow control valves). The sensor should always be filled with liquid (even when there is no flow).

In case the flow sensor cannot be mounted vertically, it is OK to mount it in ANY convenient orientation. The flow sensor will function satisfactorily when mounted in ANY orientation. However, the person installing the unit must ensure that no bubbles get trapped in side the sensor tube and the fluid does not have solid particles that would sediment inside the sensor tube section.

Inline Ultrasonic Flowmeter

Controller

The controller module can be panel mounted as shown in figure4 below

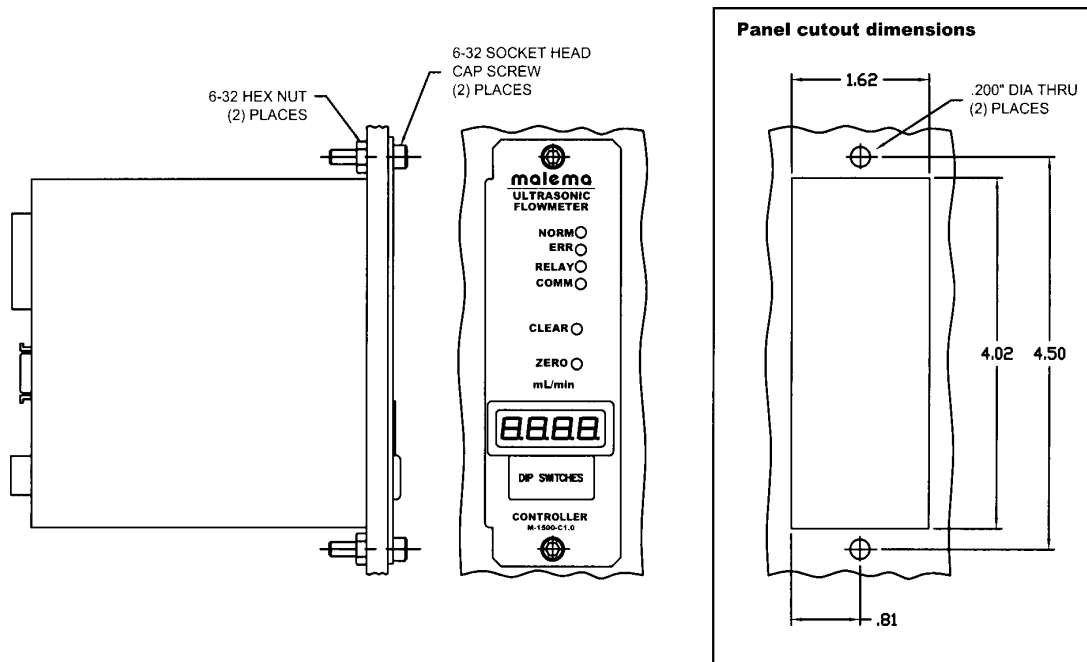

CONTROLLER MOUNTING DETAIL

Figure 4

CAUTION

All possible electric noise sources in the vicinity of flowmeter, such as motors, pumps, power relays or solenoid valves, should be fitted with suitable surge suppressor.

Wiring

The sensor unit is supplied with a 6 ft cable (standard). The connector at the end of the sensor cable needs to be connected to the controller box at the location marked “SENSOR”.

NOTE: The sensor should be connected to the controller **BEFORE** supplying power to the unit. Failure to do this will result in malfunction of the unit. In case this sequence is not followed – please power the unit down – disconnect and reconnect the sensor connector and then power the unit up.

The figure below shows the connector located on the back of the controller. The description of each terminal is listed on the figure 5.

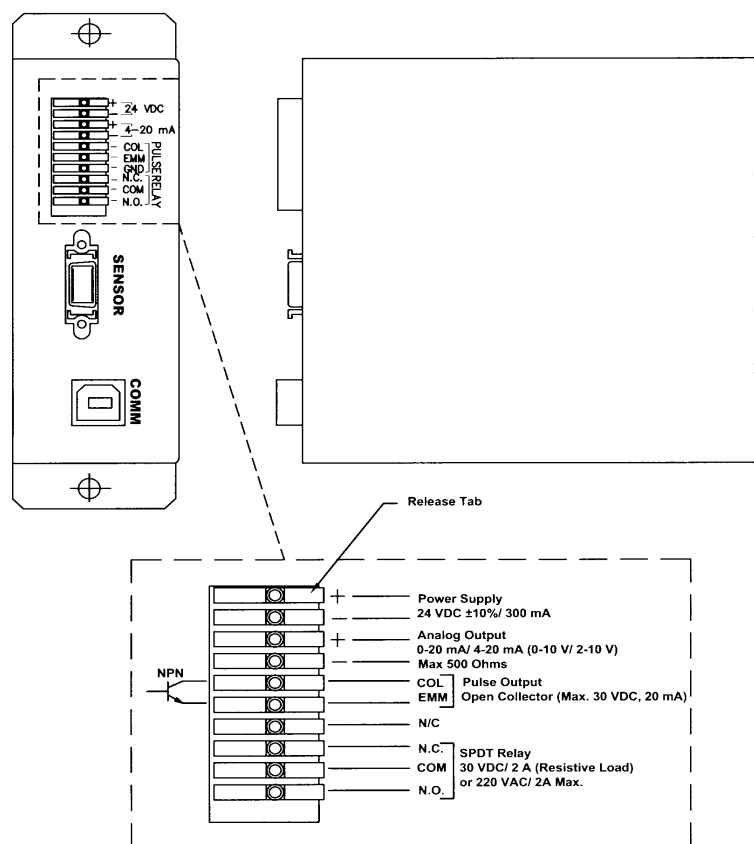

Figure 5

Please use electrical conductors of size AWG 24-20 stripped and tinned about 5 mm. These can be inserted into the respective terminal hole. The terminal block has self-locking mechanism that will bind on the stripped electrical wire. To release the conductor, press the respective tab next to the terminal hole.

Caution: Check voltage supply to be 24 VDC **BEFORE** connecting to the unit. Excessive/incorrect voltage can cause permanent damage to the unit.

Inline Ultrasonic Flowmeter

Pre - Start-up Check

Confirm the following before turning power on

- Wiring corresponds with figure 5
- Make sure the flow sensor and the controller serial numbers match.
- Verify cable connection between sensor and controller for the ultrasonic flowmeter is secure. Ensure that the connector is locked on with a positive “click”.
- Make sure the sensor and the controller are connected before powering the unit.
- Power supply voltage at terminal is $24 \text{ VDC} \pm 10\%$
- Flow direction corresponds with arrow mark on the flow sensor.
- Flow detector is completely filled with liquid. Confirm no leakage, no bubbles and no deposits are observed. If there are bubbles, eliminate them by flushing.

Zero Set

It is always advisable to “Zero Set” during initial installation – before starting ANY flow measurements. Please follow the procedure listed below to ensure that the ZERO set is done in the proper sequence.

Caution: *Incorrectly “ZERO” set on the flow meter would give erroneous readings.*

- Flow liquid continuously to ensure ALL air bubbles are purged out (large and small bubbles).
- Shut off flow – ensure liquid inside the sensor tubing is STATIONARY.
- Verify the reading on the controller unit as “ZERO”.
- If yes, the ultrasonic flowmeter is ready to use and does not have to be “ZERO SET”
- If not – ensure that the reading is STEADY. This indicates that the flowmeter needs to be “ZERO” set.
- Press “ZERO” button on the controller while maintaining STATIONARY liquid inside the tube. You should see the reading on the controller go to zero in a few seconds
- While the flowmeter is being “ZERO SET”, the NORM led on the controller will blink. This is normal and indicates that the unit is doing internal computing. Do not begin flow liquid unless the NORM led glows steady.
- When the reading reaches zero (with stationary fluid), then the ultrasonic flowmeter is ready for use.

Calibration For Different Fluids

If there is any change in the “fluid medium” i.e any fluid other than the fluid on which the flowmeter has been factory calibrated the flowmeter needs to be “CLEAR” set so as to show flow readings.

Please follow the procedure listed below to ensure that the CLEAR set is done in the proper sequence

- Flow liquid continuously to ensure ALL air bubbles are purged out (large and small bubbles).
- Shut off flow – ensure liquid inside the sensor tubing is STATIONARY.
- Press “CLEAR” button on the controller while maintaining STATIONARY liquid inside the tube. You should see the reading on the controller display. This reading will necessarily not be zero although the fluid is stationary.
- To ensure that the flowmeter reads steady “ZERO” under stationary fluid conditions please follow the steps mentioned under the section “Zero Set”.

Trouble Shooting Guide

S. No.	Phenomenon	Possible Cause and Solution
1	Display does not show anything	No power supply. Please make sure that the tinned wires are inserted adequately deep enough into their respective terminal hole.
2	The NORM led is not lit up	Same as above
3	ERR led is continuously on	Call technical support 1-800-637-6418
4	Display shows "E"	E is displayed if the sensor tube is empty or if bubbles are entrapped inside the M-1500 sensor tube. Refer to section "Zero Set" to get valid reading on the flowmeter controller
5	Display show "Or"	"Or" is displayed if the flow inside the flow tube is greater than the specified full scale of that particular unit. Adjust the flow rate, below full scale, and the flow meter should show a valid reading
6	Display shows "----"	"----" is displayed if the flowmeter sensor is mounted in the wrong direction and flowed. Make sure the flow direction is in accordance with the arrow on the flowmeter sensor.
7	Display reading is unstable during flow conditions	Display reading can become unstable if there are micro bubbles present inside the flowmeter sensor tube. Flush the sensor tube to remove the micro bubbles and the reading should now be stable

Inline Ultrasonic Flowmeter

Operation and Features

The flow sensor, once set-up, will monitor and report liquid flows. The section below lists the various functions that may be set by DIP Switches located on the front panel of the flow meter CONTROLLER

DIP Switch Setting	Function	Switch Position
1	Factory Preset "ON"	Do Not Switch
2	Factory Preset "ON"	Do Not Switch
3	Low Flow Cutoff (% F.S)	ON- Low cutoff off OFF- Low cutoff on
4	Flow Direction	ON - Reverse OFF- Forward
5	Full Scale Flow	ON- Low Flow Range OFF- High Flow Range
6	Output Time Constant	See Table Below
7	Output Time Constant	See Table Below
8	Output Time Constant	See Table Below

Time Constant Settings

DIP SWITCH 6	DIP SWITCH 7	DIP SWITCH 8	Output Time Constant	STATUS
ON	ON	ON	0.5 Sec	
ON	ON	OFF	1.0 Sec	
ON	OFF	ON	2.0 Sec	FACTORY SET
ON	OFF	OFF	2.5 Sec	
OFF	ON	ON	3.0 Sec	

Maintenance

The M-1500 flow meter has a no moving parts and if set up correctly, should not require any maintenance. Since it has no moving parts there is no wear and tear in M-1500 ultrasonic flowmeter. However, we recommend the following to ensure smooth and reliable operation

- Check for leakage around pipe connections or liquid penetration into the flow sensor.
- Check for mechanical stress to flow sensor, which could be caused by wrapping of connecting pipes or loose connections cause by mechanical vibration of pipes.